

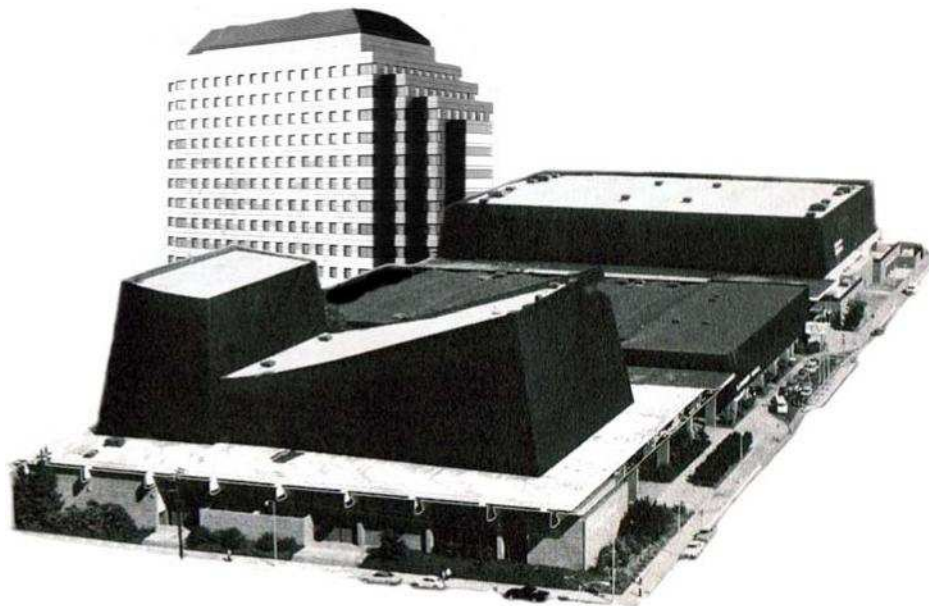

**BARBERSHOP HARMONY SOCIETY
SPEBSQSA, Inc.
FAR WESTERN DISTRICT**

2010
SPRING/DIVISIONAL
FAR WESTERN DISTRICT
CONVENTION REGULATIONS
MANUAL



REVISED MARCH 01, 2010

Fritz Grunenwald/Dick Girvin
FWD Convention Manual Administrators

2010 SPRING/DIVISIONAL CONVENTION MANUAL CONTENTS

GENERAL INFORMATION – FALL CONVENTIONS CONVENTION JOBS/TIMELINES - EXHIBITS/ SAMPLES THEATER - TECH GUIDES/EXHIBITS/SAMPLES ADMINISTRATIVE FORMS CONVENTION BID PACKAGE

Manual/Forms/Budget

Cover	1
Manual Contents	2-4
Preface/Revision Record	5
Glossary of Terms	8-10

PART A SPRING/DIV. GENERAL INFORMATION 11

Table of Content	6-7
Section 1. General All Conventions	11-13
Section 2. General SPRING/DIV. Conventions	14-25

PART B SPRING/DIV. CONVENTION JOBS26

Section 1. GENERAL CHAIRMAN TASKS	26	
Tasks/Timeline	Exhibit	JTE-01-SD 27
Operational Schedules	Exhibit	JTE-02-SD 28-31
Section 2. COMMITTEE CHAIRMEN TASKS JOB/TIMELINES.....	32	
Afterglow	Exhibit	JTE-03-SD...33
Auditorium House	Exhibit	JTE-04-SD...34
Auditorium Stage	Exhibit	JTE-05-SD...35-36
Awards	Exhibit	JTE-06-SD...37
Finance	Exhibit	JTE-07-SD...38
Graphics/ Printing	Exhibit	JTE-08-SD...39-40
Host	Exhibit	JTE-09-SD...41
Housing	Exhibit	JTE-10-SD...42-43
Judges Services	Exhibit	JTE-11-SD...44-45
Meetings	Exhibit	JTE-12-SD...46-47
Movement/Monitor	Exhibit	JTE-13-SD...48
Photography/Audio/Video	Exhibit	JTE-14-SD...49
PR/Communications	Exhibit	JTE-15-SD...50
Registration	Exhibit	JTE-16-SD...51-52
RV	Exhibit	JTE-17-SD...53
Secretary/Communications	Exhibit	JTE-18-SD...54
Signage	Exhibit	JTE-19-SD...55-56
Special Events	Exhibit	JTE-20-SD...57
Transportation	Exhibit	JTE-21-SD...58

Section 3. ADMINISTRATIVE EXHIBITS		59
15-Year Calendar	Exhibit	AE-01-SD....60
Bid Manual	Exhibit	AE-02-SD....61-65
BOD Configuration	Exhibit	AE-03-SD....66
For Hire Prices	Exhibit	AE-04-SD....67
HOD Configuration	Exhibit	AE-05-SD....68
Judging Area	Exhibit	AE-06-SD....69
Judging CJ Forms	Exhibit	AE-07-SD....70-77
Plateau Format Info	Exhibit	AE-08-SD....78
Registration Area	Exhibit	AE-09-SD....79
VIP Aud. Seating Chart	Exhibit	AE-10-SD....80
VIP Housing List	Exhibit	AE-10-SD....81

Section 4. ADMINISTRATIVE SAMPLES		82
Ad Westunes	Sample	AS-01-SD83
Art (logos, etc.)	Sample	AS-02-SD84
Awards	Sample	AS-03-SD85
Badge-Registration	Sample	AS-04-SD86
Bank Deposit Form	Sample	AS-05-SD87
Bid Form	Sample	AS-06-SD 88-91
Budget Preliminary	Sample	AS-07-SD 92-93
Budget Revised	Sample	AS-08-SD 94-95
Budget Statement Final	Sample	AS-09-SD 96-97
Flyer	Sample	AS-10-SD.....98
Host Letters	Sample	AS-11-SD.....98-100
Judge Chairman Check List	Sample	AS-12-SD101
Judge Expenses Form	Sample	AS-13-SD102
Program	Sample	AS-14-SD 103-106
Schedule of Events	Sample	AS-15-SD107
Signage	Sample	AS-15-SD108
Voucher	Sample	AS-16-SD109

PART C SPRING/DIV. THEATER GENERAL INFO.....110

Section 1. PRODUCTION DIRECTOR/STAGE MGR.....		111
Tech Guide	Guide	TG-01.....111-116
Sound Guide	Guide	TG-02.....117-124
Lighting Guide	Guide	TG-03.....125
Stage Glossary	Guide	TG-04.....126-129
Section 2. THEATER EXHIBIT		130
Riser Layout 11-9-6	Exhibit	TE-01..... 131-134
Staging Chorus/Qt.	Exhibit	TE-02135
Movement Chorus/Quartet	Exhibit	TE-03.....136
Section 3. THEATER SAMPLES		137
Monitor/Schedule	Sample	TS-02138-140
Check List	Sample	TS-01141-142

PART D SPRING/DIV. ADMINISTRATIVE FORMS

This part of the manual is only available on the Convention Manual CD and FWD Web Page in Word & Excel format.

Section 1. ADMINISTRATIVE FORMS	Form	(x=Excel)
Convection Bid	Form	AF-100-SD
Preliminary Budget	Form	AF-101x-SD
Revised Budget	Form	AF-102x-SD
Final Statement	Form	AF-103x-SD
Registration Accounting	Form	AF-104x-SD
Section 2. SCHEDULE FORMS		(x=Excel)
General	Form	AF-200-SD
Quartet Move	Form	AF-201x-SD
Chorus Move	Form	AF-202x-SD
Back-stage Ch/Show (Micro)	Form	AF-203x-SD
Section 3. REGISTRATION FORMS		
Single	Form	AF-300-SD
Bulk Seat	Form	AF-301-SD

PART E SPRING/DIV. CONVENTION BID PACKAGE

This part of the manual is only available on the Convention Manual CD and FWD Web Page in Word & Excel format.

Section 1. Manual	Exhibit	AE-02-SD
Bid	Form	AF-100-SD
Preliminary Budget	Form	AF-101x-SD

-End of Manual Contents -

PREFACE

The Divisional Contest that is held coincident with the Spring International Quartet Preliminaries is governed by the FWD current *Spring/Divisional* Convention Regulations Manual. All other Divisional Contests, not combined with the Spring contest, will be governed by the procedures and forms in the *Divisional* Convention Regulations Manual.

The FWD Board of Directors in 1997 resolved that beginning in 1999, all conventions/contests will be run by a district management team with selected chapters being offered a fixed fee for providing personnel and services.

In addition, it was agreed that a series of "permanent" venues in the several geographic areas to be identified and steps be made to obtain long term multi-year contracts with the obvious stabilizing effects.

These events, as run by the district management team, will be in adherence to the rules/procedures currently in practice and the manual has been revised to include the special language needed to assure proper conduct and implementation of the policies and practices embodied herein.

It should be noted that chapters that wish to bid to conduct conventions/contest are welcomed and encouraged to do so and their bid(s) will be reviewed in the light of the standing rules/procedures of this document.

In brief, the normal approach will be "district run conventions" and the exceptions will be "chapter-run" events as they are proposed and are accepted by the FWD Board of Directors.

FWD SPRING/DIV. CONVENTION REGULATIONS MANUAL REVISION RECORD

Revision	Date	Authority	Date
Rev. 0 Combined	March 1996	FWD Board	Board Meeting 03/96
Rev. 1 Combined	January 1998	FWD Board	Board Meeting 10/97
Rev. 2 Combined	June 1998	FWD Board	Board Meeting 06/98
Rev. 3 Combined	October 1998	FWD Board	Board Meeting 10/98
Rev. 4 Combined	January 2000	FWD Board	Board Meeting 03/99
Rev. 5 Combined	January 2001	FWD Board	Board Meeting 03/01
Rev. 6 Combined	January 2002	FWD Board	Board Meeting 10/02
Rev. 7 Combined	January 2004	FWD Board	Board Meeting 03/04
Rev. 8 Combined	January 2005	FWD Board	Board Meeting 03/05
Rev. 9 Combined	January 2006	FWD Board	Board Meeting 03/66
Rev. 10 Combined	January 2008	FWD Board	Board Meeting 03/08
Rev. 11 Spring/Div.	March 2010	FWD Board	Board Meeting 03/10

PART A TABLE OF CONTENTS

GLOSSARY OF TERMS.....	8-10
PART A ALL FWD CONVENTIONS	11
Section 1.	
11. General	11
1.1.1. Divisional Definition.....	11
1.1.2. Spring/Divisional Definition.....	11
1.1.3. Fall Convention Definition.....	11
12. Forward.....	11-12
13. Philosophy.....	12
14. Key Personnel	12-13
PART A SPRING/DIV. FWD CONVENTIONS	14
Section 2	
21. General -	14
2.1.1. SPRING/DIV. Convention Roles.....	14
2.1.2. General Chairman's Role	14-15
2.1.3. Job Descriptions/Timelines.....	15
2.1.4. Awards.....	15
2.1.4.1. Awards Non-Competitive	15
2.1.5. Bidding Procedures.....	16
2.1.5.1 Bidding - To Whom Bids Submitted	16
2.1.5.2 Bidding - Profit Split	16
2.1.6. Contest Entries.....	16-17
2.1.6.1. Contest - Order of Appearance.....	17
2.1.7. Dedication.....	17
2.1.8. Disabilities.....	17
2.1.9. Events	18
2.1.9.1 Events - Board Of Directors Meeting... 	18
2.1.9.2 Events - House Of Delegates Meeting... 	18
2.1.9.3 Events - Contest Evaluations Sessions	18
2.1.9.4. Events - Special Events	18
2.1.9.5 Events - Youth In Harmony (YIH) Rm 	18
2.1.9.6. Events - Afterglow	18
2.1.10. Facilities.....	19
2.1.10.1. Facilities - Auditorium 	19
2.1.10.2 Facilities Auditorium House Committee 	19
2.1.10.3 Facilities - Auditorium Stage Committee 	19
2 . 1 . 1 1 . F i n a n c e 	1 9

PART A SPRING/DIV. FWD CONVENTIONS
Section 2 Cont.

2.1.12.	Hosting	20
2.1.13.	Housing.....	20
2.1.14.	Insurance.....	21
2.1.15.	Judges Services.....	21
2.1.16.	Licensing	21
2.1.17.	Master of Ceremonies.....	21
2.1.18.	Medical.....	21
2.1.19.	Photography.....	22
2.1.20.	Printing/Graphics.....	21-22
2.1.20.1.	Printing/Graphics - Signage	22
2.1.21.	Publicity and Public Relations	22
2.1.22.	Recording.....	22
2.1.23.	Recreational Vehicles.....	23
2.1.24.	Registration.....	23-24
2.1.24.1.	Registration - Cost.....	24
2.1.24.2.	Registration - Reserved Seating (n/a)	24
2.1.24.3.	Registration - Patron	24
2.1.25.	Schedule Overall.....	24
2.1.25.1.	Schedule General.....	24
2.1.26.	Security.....	25
2.1.27.	Transportation.....	25

-End Table of Contents-

GLOSSARY OF TERMS

Definitions of terms used in this manual are as follows:

ACA - Associate Contest Administrator

AFWDC - Association of Far Western District Champions (quartet).

CA -Contest Administrator is the Chairman of the Judging Panel. He is in complete charge of the contest until the announcements have been made of the final standings of the competitors.

CEC - Chairman of the Events Committee

The District Chairman in charge of all FWD events including contests, conventions, seminars, etc.

College Quartet Contest

The contest held at any of the five Divisions and the district Spring Conventions, to select a College Quartet Champion (and Medalist Quartets). The winners may represent FWD in the succeeding International College Quartet Contest.

CES - Contest Evaluation Sessions: The Contestant Evaluation Sessions are held as determined by the Chairman of the C&J Committee (DRCJ) and the Contest Administrator immediately following contests to provide contestants special evaluation by the scoring judges.

CC - Chapter Counselors. Senior consultants for chapter support as needed. Reporting to the Division Vice Presidents of their respective divisions.

CRC - Convention Registration Chairman

CS - Convention Secretary.

CSM - Convention Stage Manager

DRCJ - District Representative Contest & Judging

The District Chairman in charge of all Contest and Judging activities.

DEP - Divisional Events Planer - The District Events Chairman shall annually appoint a Division Event Planner (DEP) for each Division to approve venues and supervise/support conventions and contests that are held in the Division. The DEP will be part of the Division VP's management team and may act for the District Events Chairman (when requested) to find or approve venues for meetings and functions held in the division.

DET - District Events Team - The permanent FWD team charged with the conduct of District events and those divisional contests for which no chapter sponsor has been approved. This team contains highly trained, specialists that perform in their specific capacity to either conduct or advise chapter hosts on how to conduct a divisional contest. Key personnel for the Events Team include: Executive General Manager (**ETEGM**), Spring General Manager (**SGM**), Fall General Manager (**FGM**) and consultants. Other important Events Team personnel include but are not limited to Accounting Manager, Meetings Manager, Monitor Manager and Registrations Manager,

District - General reference to the FWD, one of 16 geographical subdivisions of chapters in the BARBERSHOP HARMONY SOCIETY, Inc. (BHS).

District Plateau Awards - Awards to be presented to those district choruses achieving the highest scores in each of three plateau levels: The plateaus are based on scores previously achieved and adjusted annually.

Division - A geographically designed locale within the boundaries of the FWD, each with assigned chapters. At present, there are five Divisions: Div. 1: **Southwest (SW)** Southern California West; Div. 2: **Southeast (SE)** Southern California East; Div. 3: **Northwest (NW)** Northern California West/Hawaii; Div. 4: **Northeast (NE)** Northern California East, and Div 5 **Arizona** Division: Arizona.

Division Contest - A contest held in each Division to qualify quartets and choruses that will represent the Division at the Fall District Contest. These contests are held in April and May according to the calendar, prepared by the District (Exhibit AE-01).

DP - District President.

DPD - District Production Director The District Production Director is responsible for the coordination, planning and execution of the on-stage portions of the convention/contest activities.

DTS - Designated Target Score

The score, which qualifies a quartet/chorus, to compete at the next level contest. The District Board for District contests and the Society Contest and Judging Committee, for the International preliminary contests, establish these "target scores".

Fall District Contest - A contest to select a District Quartet Champion. A District Chorus Champion that will compete at the succeeding International Chorus Contest. Additional Choruses may be chosen to advance to the International Chorus Contest by Society Board Policy. This contest is normally held on the second weekend in October. This contest is also referred to as the Fall District Contest. The District Chorus representative that succeeds in winning the International Chorus Contest is not eligible to compete in the District for three years.

FWD - The Far Western District Association of Chapters BARBERSHOP HARMONY SOCIETY Inc. (BHS).

GCC or GCM - General Convention Chairman The representative of the Host Chapter or General Convention Manager Events Management Team, responsible to the Chairman of the Events Committee (CEC) for the conduct of the convention.

High School Quartet Contest - A special quartet contest for male high school students held at the Spring District Convention/Contest to select an FWD High School Quartet Champion and Medalists Quartets.

Ineligible Members - Society members to be eligible to compete with the chorus or quartet must meet eligibility rules as found in the current Society C&J Rules. Art I.

Ineligible Quartets - No previous District, International Champion or Senior Quartet is allowed to compete for the championship, which it holds. Nor more than two members of the same District, International Champion or Senior Quartet may compete in a new quartet even though they compete with a different quartet name.

International Preliminary Quartet Contest -The Contest to qualify by the score established by the International C&J Committee, those quartets that will represent the FWD in the succeeding International Quartet Contest. This is an International Contest conducted by the FWD. It is normally held on the third weekend in March. It is also known as the Spring District Contest or the "International Prelims."

Novice Quartet - A quartet containing no more than two members who have sung in a FWD Fall District Contest.

Senior Quartet Contest - The contests are held at the five divisional contests. The five highest scoring Senior Quartets (all members must be at least 55 years of age at the time of the International Senior Quartet Contest and the total for the quartet must equal or exceed 240) from the divisional contests will advance to the Fall Senior finals. At the Fall contest, these five senior quartets compete for the District Senior Championship. The highest scoring Senior Quartet in the Fall Contest will be funded as described in the FWD SOP 8.3.2.2.2 and will have the honor of representing the FWD at the succeeding International Senior Finals (Midwinter convention site.)

Super Senior Quartet Contest – The contests are held as part of the five divisional contests. The highest scoring Super Senior Quartet (all members must be at least 65 years of age and the total ages of the quartet members much equal or exceed 280 at the time of the contest). is identified as the *District Super Senior Quartet Champion* and will be invited to sing in the Fall Show of Champions.

-End of Glossary of Terms-



**BARBERSHOP HARMONY SOCIETY
SPEBSQSA, INC.**

FAR WESTERN DISTRICT

PART A – SECTION 1

GENERAL INFORMATION

ALL FWD

CONVENTIONS/CONTESTS

1.1 General To All FWD Convention/Contests

The proper conduct of any FWD Convention/Contest is an extremely complex activity involving large numbers of highly trained men with special preparation in their respective disciplines. The **overall** FWD Convention Manual is, therefore, necessarily a well detailed and a very large document. For this reason the overall manual has been broken into separate manuals pertaining to each individual type convention. Host chapters, however, will only require the manual that involves their individual hosting activity i.e., specific Divisional Convention/Contest, Spring/Divisional International Prelims, or Fall Convention/Contest.

1.1.1. FWD Divisional Convention/Contests Manual: contains duties necessary to conduct all Convention/Contests and those unique instructions, job descriptions/time lines, forms, exhibits and samples pertaining **only to the FWD Divisional Convention/Contests.**

1.1.2. FWD Spring/Divisional (Int. Prelims, Etc.) Conventions/Contests Manual: contains duties necessary to conduct all Convention/Contests and those unique instructions, job descriptions/time lines, forms, exhibits and samples pertaining **only to the FWD Spring/Divisional Convention/Contests.**

1.1.3. FWD Fall Convention/Contests Manual: contains duties necessary to conduct all Convention/Contests and those unique instructions, job descriptions/time lines, forms, exhibits and samples pertaining **only to the Fall Convention/Contests.**

The aggregate of these parts comprise the established regulations for Far Western District Spring, Divisional and Fall Convention/Contests and where applicable, constitutes an agreement between the chapter that has been officially awarded the host opportunity and the FWD Board of Directors. These regulations identify the responsibilities and requirements of both parties to assure a successful event.

1.2. Foreword

Each manual of Convention Regulations is included by reference and thus are a part of the Far Western District's Statement of Policy (SOP). The manuals cover all aspects of district and divisional conventions including the associated contests, meetings and activities scheduled for the district Spring/Divisional and Fall Conventions as well as Divisional activities. Each is covered in a separate part containing all of the forms, exhibits and samples needed for the respective Convention/Contest.

These manuals identify the procedures necessary to conduct successful conventions and contests. A complete and thorough understanding of these procedures will facilitate the conduct of the events starting with the bidding process, resulting in a contract and agreement between host chapters and the Far Western District and the successful accomplishment of the activity. These regulations are applicable to all official contests and conventions listed above.

Further, these manuals point out the work, which must be done by host chapters when awarded a convention. Should additional information be needed or deviations from the protocol provided, the Events Committee Chairman (CEC) should be contacted. Assisting the Events Chairman are the Divisional Events Planners (DEP's) who are appointed by and report to the Chairman of the Events Committee (CEC) who is responsible to the FWD Board of Directors to insure a smooth, successful convention and has the authority to sign contracts, modify requirements and to obligate the district in such matters.

These regulations cover the fundamentals necessary to plan, bid for and execute a successful convention. But in the long run, it is the desire and the extra touches of hospitality provided by the host chapter that make a successful convention an outstanding convention for the host chapter as well as each registrant and participant.

These documents are available on CD-ROM PDF formatted and (MS-Word and Excel formatted) to Convention/Contest conduct personnel (i.e., Convention Managers) from the FWD Convention Manual Administrator (Fritz Grunewald) or District Chairman of the Events Committee. Note: Also available on the **FWD Web Page** (www.spebsqsafwd.org).

All FWD Convention Chairmen are required to have a copy of the Manual pertaining to the specific Convention/Contest they are assigned to.

In addition, by district policy, all **FWD General Convention Chairman must have completed the special course offered at district schools**, (or otherwise provided by the Chairman of the Events Committee) within the past two years prior to their assigned convention.

1.3. Philosophy

Before proceeding with the details and fundamentals of convention planning, it is beneficial to review the philosophy of the Far Western District with respect to conventions. The basic goals for a successful convention are:

- *To provide for the comfort and enjoyment of all attendees, including contestants, judges, dignitaries (elected or appointed), visiting VIPs, the families of all the above;*
- *To provide a profitable financial return for the Far Western District and the hosting chapter;*
- *To provide the District and the chapter the best and widest media coverage;*
- *To encourage participation by all district membership;*
- *To strive for the best and largest attended convention to date.*

When one accepts this basic philosophy it should not be difficult to follow the step-by-step procedures outlined in the appropriate parts of each manual and have a greater understanding of the big picture. If everyone performs their assigned tasks, the convention will be a success for the host chapter as well as the district. The secret to success is communication (internal and external) and marketing.

1.4 Key Personnel

The key personnel that are involved in the preparation and conduct of conventions are listed below, and should be copied in on all convention correspondence.

a. District President (DP)

The FWD President is responsible to the district membership producing a successful convention and contest.

b. Chairman of the Events Committee (CEC)

The function of the CEC is to lend guidance and assistance to the FWD Events Team, and the Host Chapter. Divisional Events Planners (DEP) may act in behalf of the FWD Chairman of the Events Committee (CEC) to insure a smooth running and financially successful event.

c. Divisional Events Planning Manager (DEP)

The District Events Chairman appoints a Division Event Planner (DEP) for each Division to approve venues and supervise/support conventions and contests that are held in the Division.

d. General Convention Chairman (GCC)

The General Convention Chairman is appointed and is responsible to the Chairman of the Events Committee (CEC) to ensure a successful and profitable convention.

e. District Representative Contest and Judging (DRCJ)

District Representative Contest and Judging (DRCJ) represents the Society Contest and Judging Committee and is responsible for the district contestant registration details, judging panel details, approval of theater sound/lighting and evaluation sessions.

f. Contest Administrator (CA)

The Contest Administrator is responsible for the orderly management and operation of the contest sessions of the convention. The Society C&J Committee assigns him.

g. Convention Secretary (CS)

The Convention Secretary is part of the host team for the specific convention/contest. He takes minutes, handles correspondence, and provides a repository for all documentation generated for the event.

h. District Production Director (DPD) or Convention Stage Manager (CSM)

The District Production Director or Convention Stage Manager is responsible for the coordination, planning and execution of the on-stage portions of the Convention/Contest activities.

i. Convention Registration Chairman (CRC)

The Convention Registration Chairman is responsible to the General Convention Chairman for processing all individual, quartet and chorus registrations and name badges.

-End of General To All-



**BARBERSHOP HARMONY SOCIETY
SPEBSQSA, INC.**

FAR WESTERN DISTRICT

**PART A - SECTION 2
GENERAL INFORMATION
SPRING/DIVISIONAL ONLY
CONVENTIONS/CONTESTS**

2.1. SPRING/DIVISIONAL Conventions

The Far Western District Spring/Divisional. Convention/contests are held annually in October. The Spring/Divisional Convention/contests include a number of contests, meetings and specials events.

2.1.1. SPRING/DIVISIONAL Convention Roles

There are a number of major roles for the successful operation of all FWD Spring/Divisional Convention/Contests. In addition to the general information, specific additional information regarding the Spring/Divisional Conventions will be provided here.

2.1.2. General Convention Chairman

Because the job of the General Convention Chairman is the key position in the Spring/Divisional Convention/Contests, additional descriptive material is provided in this section. The General Convention Chairman is responsible to the Chairman of the Events Committee (CEC) for a successful convention and follows the Convention Regulations, which reflect District Policy.

He prepares and submits the Contest Bid and updates the budget, in conjunction with the Finance Chairman, and is responsible for all expenditures. He must see that all timetables are adhered to and the results reported in a timely manner.

He must approve and sign all reports and insure that the final report is submitted within the time limit prescribed by these regulations and the District Standing Operating Procedures (SOP). He schedules timely meetings for the entire committee (general), and as needed with specialized committees. A published schedule of date, location and time for each general meeting will be furnished each committee member, Chairman of the Events Committee (CEC) and District President.

SPRING/DIVISIONAL CONVENTION GENERAL INFORMATION

ACTIVITY	ACTION
Bid Form:	Form 100-SD
When To Bid:	3 Years Prior
Bid Submitted To:	Chairman of the Events Committee (CEC)
Bid Approved	Chairman of the Events Committee (CEC)
Split Chapter/District:	30% Chapter - 70% District Minimum
District Events Team Run	Chapter For-Hire (Flat Fee)
Registration Fees:	Adult All Event Early Bird - \$40.00/\$50.00 Late/On Site Youth All Events (under 26) Early Bird - \$20.00/\$30.00 Late/On Site Non-member Child (12 and under) Free (Members this young use Youth rates) On Site Charge - Single Event \$30.00 Each - Sold On Site Only All competitors must have All Events Registration for their age group.
Auditorium	1200 Seats Minimum
Hotel Rooms	300 minimum
Meeting Rooms	FWD Board Thursday evening FWD Board Friday morning HOD Friday afternoon Others as required.
Draw for the quartet/chorus	General Convention Manager – 14 Days Prior To Contest
Draw High School/College Qt's	At Site

Table 3-1

2.1.3. Spring/Divisional Convention Job Descriptions

The detailed duties, responsibilities and time-lines of the Convention/contest Committees are provided in (Part B, Section 1 & 2). Those Tasks and Timelines are designed to be copied and given to the assigned personnel.

The following listings are in alphabetical order.

2.1.4. Awards

A number of important awards are made during the weekend of the Spring/Divisional Convention. They are classified into two sections: (1) Competition Awards and Non-Competition Awards. Table 3.2 provides a summary of these awards.

2.2.4.1 Competition Awards

The awards presented at the Spring/Divisional Convention are as shown above.

2.2.4.2 Quartet Competition Awards

The quartet competition awards presented include:

- International Preliminary Quartets making qualifying score are identified
- Divisional Quartet Champion
- Divisional Novice Champion
- High School Quartet Champion

(Note: Senior and Super Senior Quartets are included in the contestants, however no specific awards are made at the divisional level. The top five scoring Senior Quartets are seeded to the Fall Convention/contest to vie for the District Senior Champion title (one-time only). The top scoring Super-Senior of the five divisionals is invited to sing in the Show of Champions at the Fall Convention/Contest. The scores for all college quartets that compete in the divisionals are forwarded to Nashville for selection for the International

2.2.4.3 Chorus Competition Awards

The chorus competition awards presented include:

- Divisional Chorus Champion
- Divisional Plateau A *Winner
- Divisional Plateau AA* Winner
- Divisional Plateaus AAA* Winner
- Most Improved Chorus

*Awarded in accordance with the plateau program approved by the HOD October 2005.

2.2.4.4 Non-Competition Awards

Non-Competition Awards include: *Achievement Awards, Chapter Counselor of the Year, Chapter of the Year, Contest and Judging Awards, Convention Dedication, District Chapter of the Year, District Bulletin Editor of The Year, Hall Of Fame Award* (when applicable), President's special awards and other district awards as necessary. . Specific awards are provided as indicated in Table 3.2. The presiding officer makes the presentation.

SPRING/DIVISIONAL CONVENTION/CONTESTS AWARDS

SPRING/DIVISIONAL Competition Awards	Type/ Traveling Trophy/Misc.	Type/ Plaque	Type/ Certificate/Etc.
Division Quartet Champion	Traveling Trophy	4 Plaques	Competitors making "Target Score" advance to the Fall Contest
Division Novice Champion			
Division Chorus Champion	Traveling Trophy		
Top Scoring Plateau A Chorus		1 Plaque	
Top Scoring Plateau AA Chorus		1 Plaque	
Top Scoring Plateau AAA Chorus		1 Plaque	
Most Improved Chorus	Traveling Trophy		
College Quartet	None	None	Scores forwarded Kenosha
High School Qt. Champions	4-Trophies		Cert. All Participants
2nd Place High School Qt.	4-Trophies		Cert. All Participants
3rd Place High School Qt.	4-Trophies		Cert. All Participants
International Qualifying Qts.	(Advance to Int. Contest)		Letter/District Travel Funds
Totals	15 Trophies	7 Plaques	All HS Participants
Non-Competition Awards	Where Awarded	Type/ Plaque	Type/ Certificate/Misc.
Achievement Award	House Of Delegates		Certificate
Chapter Counselor Of The Year	House Of Delegates	Plaque	
C&J Award, as applicable	House Of Delegates	Plaque	
Bulletin Editor Of The Year	House Of Delegates	Plaque	
Chapter Of The Year	House Of Delegates	Plaque	
Secretary of The Year	House Of Delegates	Plaque	
Hall Of Fame Award	Show Of Champions	Plaque	
President's Award	Show Of Champions	Plaque	
Convention Dedications	Show Of Champions	Plaque	
Totals	HOD or SOC	8 Plaques	Various Certificates

Legend: HOD: House of Delegates, Friday afternoon. SOC: Show Of Champions, Saturday
 Table 3.2

2.1.5. Bidding Procedures

A chapter bidding to host a Spring/Divisional Convention/contests shall follow the instructions provided in the Spring/Divisional Bid Package available in (Part E, Section 1) **on the Convention Manual CD and FWD Web Page in Word & Excel format** and also may be obtained from the Chairman of the Events Committee (CEC). Bids for all FWD Spring/Divisional Conventions, shall be made on Form AF-100-SD (See Part D Section 1) **available on the Convention Manual CD and FWD Web Page in Word & Excel format** and all bids must be accompanied by a preliminary budget on Form AF-101-SD (see Part D Section 1).

2.1.5.1. To Whom and When Bids Must Be Submitted

Bids for the Spring/Divisional Convention/contests are submitted to the Chairman of the Events Committee on or before January 1, three years prior to the year for which the bid is being submitted. If no bids are received by 1 year in advance, the **District Events Team (DET)** will run the Spring/Divisional Convention/contests.

Prior approval of the proposed auditorium to be used for the contest venue is required by the District Representative Contest & Judging or his appointed representative following a site inspection. Bids for all conventions and contests must conform to the pre-approved dates as listed in the FWD 15 Year Calendar (See Exhibit AE-01-SD). Bids will be awarded only to incorporated, chartered chapters in good standing.

2.1.5.2. Profit Split Chapter/District

The District's share of the net profit from the Spring/Divisional Convention shall be no less than **70%** seventy per cent.

2.1.6. Contest Entries

Annually the District Representative Contest & Judging (DRCJ) will publish a document via e-mail and on the district web site inviting quartets and choruses to participate in the Spring/Divisional, Fall and Division contests for that calendar year, informing them of locations, dates and times. Official entry blanks, (See Exhibit AE-07-SD) CJ-20, CJ-21 and CJ-22, and forms for Senior, College and High School Quartets will be on the Society website (<https://secure.spebsqsa.org/members/menu.asp>) and/or the *FWD Web Site* (www.spebsqsfwd.org). Contestants are requested to enter contest 28 days prior to the event. This action permits the DRCJ and others to properly plan the event with regard to judging panel size, etc.

Contest entry blanks and information may normally be secured from the *FWD Web Site* (www.spebsqsfwd.org). They will be mailed to quartets, chorus directors or chapter presidents only by special request to the DRCJ.

The District Representative Contest & Judging (DRCJ) will request that copies of the CJ-20 form be provided by the host chapter to those potential contestants not yet registered with the Society Office. (Additional copies of these forms are authorized.) Completing a Society entry form or entering via e-mail using the forms found on the Society <https://secure.spebsqsa.org/members/menu.asp> and/or *FWD Web Site* (www.spebsqsfwd.org), and returning it to the District Representative Contest & Judging (DRCJ) permits the quartet or chorus, if approved, to enter contests held in the District during that calendar year, Stringent penalties are currently in force requiring contestants to provide verification of the legality of the music arrangements being use in contest. Special forms are normally available on the Society website to assist in this process.

The District Representative Contest & Judging (DRCJ) has the responsibility of verifying the eligibility of each applicant prior to each contest. All entry forms must be returned to the (DRCJ) or the designated chairman by the date specified. The District Representative Contest & Judging (DRCJ) or the designated chairman will forward copies of the entry forms or the significant data to the respective GCM.

2.1.7. Order of Appearance (OOA)

The order of appearance for the several contests is shown in the following sections.

2.2.7.1. International Preliminary Contest

The drawing for the order of appearance will be conducted by the Hosting Chapter or by the Events Team (if run by the Events team). The draw will be made 21 day prior to the contest. Since the International Quartet Preliminary Contest is open to all Society Quartets except Past International Quartet Champions, the number from each district is determined by those quartets meeting the qualifying score established by the Society Board.

The Semifinal for the International Preliminary Quartet contest will be combined with the single round Final divisional quartet contest. (Note: if more than 25 total contestants are registered a second session may be scheduled.

The Entry Form CJ-20, (Exhibit AE-07-SD) must be completed via e-mail at the **FWD Website** (www.spebsqsfwd.org) and in the hands of the District Representative Contest & Judging (DRCJ) no later than 28 days prior to the contest. The General Convention Manager will conduct the drawing for order of appearance no later than 10 days prior to the contest. The General Convention Manager will make contestant notification.

2.2.7.2. Divisional Chorus, College and High School Quartet Contest

In conjunction with the Spring/Divisional Contest, the District conducts (1) Divisional Quartet and Chorus Contest and (2) a High School Quartet Contest. Current rules permit college quartets to participate at this venue. The drawing for the order of appearance for the divisional chorus contest, will be conducted by the General Convention Chairman. The Chairman of the Youth In Harmony Committee will conduct the order of appearance for the High School Quartet Contest. The order of appearance for College Quartets will be integrated with the International Preliminary/Division Quartet contest draw.

The Entry Form CJ-20, (Exhibit AE-07-SD) for choruses, must be completed via e-mail at the **FWD Website** (www.spebsqsfwd.org) and in the hands of the District Representative Contest & Judging (DRCJ) no later than 28 days prior to the contest. Entry forms for the High School Quartet contest and for the College Quartet contestants are established by district and Society policy, respectively.

2.1.8. Dedication

It has been the practice of the Far Western District to dedicate conventions to outstanding persons of the District. The FWD Awards Committee a number of years in advance of the convention/contests determines these dedications. Posthumous dedications are sometimes made. Where possible the person honored by the FWD is provided for himself and one guest, registration and room accommodations at the headquarters hotel as a convention expense. A suitable plaque is presented during the Saturday night Show of Champions.

2.1.9. Disabilities

Special arrangements are to be made to accommodate disabled Barbershoppers, their families and patrons at the convention/contest sessions. A special wheelchair section and ramps will be provided at all convention/contest sessions in keeping with current American Disability Association's (ADA) guidelines. Some type of transportation (golf cart, etc.) should be made available to contestants with walking problems to get from dressing rooms to stage and back. Hotel accommodations for the disabled will be provided in accordance with the ADA guidelines.

2.2.10. Events.

The events scheduled for the Spring/Divisional Convention/Contests include: competition, meetings and special activities. Table 3.3 summarizes these events. These events will be listed on the convention schedule and space provided in accordance with requirements found on Table 3.4.

SPRING/DIVISIONAL CONVENTION/CONTESTS EVENTS

SPRING/DIVISIONAL Competition	Meetings	Special Activities	
International Quartets (Semifinal and Final) Division Quartets Final College Quartets	Board Of Directors	Show Of Champions	Sing-With-Champs
Division Choruses	House Of Delegates	Afterglow(s)	Trips
High School Quartets	PROBE	Hospitality Suites	Community Perform(s)
	Chorus Directors Guild	High School Glow	Ladies Hospitality
	Youth Activities	Golf Tournament	As Needed/Req.
	AH=Sow		
	Convention Team Postmortem		
	As Needed/Requested		

Table 3.3

2.1.10.1. Board Of Directors Meeting

The Board of Directors meeting room shall accommodate no fewer than 62 persons, including guests. Ten places must be set conference style and the remaining may be theater style. There must be ice water and glasses. Coffee, soft drinks and tea will be provided for the Thursday afternoon sessions. (See Exhibit AE-03-SD for full details).

2.1.10.2. House of Delegates Meeting

The House of Delegates meets on Friday afternoon to conduct the business of the District. The meeting room for the House of Delegates should accommodate at least 150 persons. (See Exhibit AE-05-SD for full details).

2.1.10.3. Contest Evaluations Sessions

The Contestant Evaluation Sessions (CES) shall be held as determined by the District Representative Contest & Judging (DRCJ) and the Contest Administrator. Other rooms will be reserved as specified by the Events GCC's schedule of events.

2.1.10.4. Special Events

The Events Team Special Events Chairman is responsible for working with the locally provided Special Events Chairman in the planning of additional activities to entertain visitors during the weekend when contest sessions are not being presented. These usually take the form of golf tournaments, tours to interesting places in the area, shopping trips, ladies hospitality activities, etc. These events are not mandatory but tend to leave a good feeling about the Host City in the minds of the visitors. Events that require a payment of some sort should be kept to a minimum. A golf tournament may require an entry fee, which must pay for the prizes and use of the facility.

2.1.10.5. Youth In Harmony (YIH)

If a Youth In Harmony (YIH) Room is planned, it is mandatory that it not be located where alcohol is available and is adult chaperoned.

2.1.10.6. Afterglow

The afterglow room should be ready on Saturday evening - 10:30 p.m. to 1:30 a.m. Seating should be arranged in theater style for 500 plus and at least two no-host bars outside the performing area.

2.1.11. Facilities

There are a number of facilities that are required to conduct a Convention/Contests to maximize the function and the fellowship activities. These facilities include the auditorium, meeting rooms and spaces and housing.

2.1.11-1. Auditorium

The auditorium for the Fall Contest should have at least 1200 seats, numbered to accommodate reserved seating. The auditorium approval for the Spring/Divisional contest is the responsibility of the Chairman of the Events Committee and the District Representative Contest & Judging. Flat floor facilities are acceptable, but not desirable.

2.1.11.2. Auditorium House Committee

This committee is responsible for badge checkers, door closers, ushers, distribution of programs and the arrangements in the judging area. This Committee is in charge of the entire building "in front of the footlights". (See Exhibit AE-06-SD & AE-11-SD).

Audience access doors must be able to be closed during contest performances. Door monitors and ushers may be wives of members or members of neighboring chapters if allowed by the auditorium.

2.1.11.3. Auditorium Stage Committee

This committee is in charge of the building "behind the footlights." (See the Detailed Technical Theater Concerns in Part C Section 1,2, & 3).

For the Spring/Divisional Convention, a Technical Information Package (including scale drawings of the auditorium showing detailed dimensions of the stage, backstage areas, front-of-house lighting positions, inventories of lighting equipment, sound equipment and draperies) should be sent to the District Production Director two months prior to the convention. Once approved, it is the responsibility of this committee to prepare a detailed diagram of the stage and risers, which should be mailed to each contestant one month prior to the convention.

2.1.12. Finance

The chapter shall be responsible for the submission and approval of a preliminary budget (Form AF-100-SD), to be submitted with the bid. A revised budget (Form AF-102-SD) must be submitted one year in advance of said convention, to the Chairman of the Events Committee (CEC) and the District Treasurer for the District board meeting preceding the convention. The preliminary budget shall be sufficiently detailed to show all expected receipts and disbursements. The revised budget will show **any changes** that have occurred since the preliminary budget was submitted.

After the CEC has approved a budget, the General Convention Chairman **shall not exceed** the amounts budgeted without approval of the Chairman of the Events Committee (CEC) or District President.

Separate banking records, or special ledger accounts within the chapter accounting system, shall be established for the duration of the convention, apart from normal chapter finances. (See Exhibit Samples AS-05-SD, AS-13-SD & AS-17-SD).

NOTE: Within **forty-five days** of the completion of the convention ,the **General Convention Chairman** must submit to the District Treasurer, with copies to the FWD Board of Directors and the Chairman of the Events Committee, a fully detailed statement of income and expenses, Form AF-103x-SD. This statement must be accompanied by a check made payable to the Far Western District, covering the District's share. If this is not accomplished, a penalty is levied in which the District's share shall increase by one percent and the chapters share decrease by one percent for each week the report is late.

The Finance Chairman should preserve all financial records of the convention for a period of **ten years**. It is highly recommended that the Finance Manager work closely with the Registration Chairman.

2.1.13. Hosting

The Host Chairman should contact each chorus and quartet by mail as soon as the draw has been finalized, introducing himself and providing them with all the information they will need. Information should include, but not be limited to, the time at which each chorus or quartet must be at the contest site, directions for getting there (map if necessary) and any other pertinent information. When the contestants arrive at the convention hotel/auditorium, they should check in at the “Contestants Table” for directions and any changes in the schedule, etc. The Host Chairman’s committee must see that each contestant gets to the auditorium, dressing room and warm up room on time. The Host Chairman may assign local chapter hosts to each competitor and he should prepare for each host, the name, address and telephone number of the contact man of his assigned contestant, plus the order of appearance, flow chart, map, etc.

2.1.14. Housing

A contract will not be entered into with any hotel limiting the number of hotels that may be advertised for housing. Hotels and motels should agree to reserve a minimum 300 rooms for a Spring/Divisional Convention. The rates of the hotel rooms should be reasonable and established by contract. Hotels used will give a firm commitment on room costs one year before advertised for housing. Acquiring this commitment in writing is mandatory according to District Policy.

SPRING/DIVISIONAL CONVENTION/CONTESTS HOTEL ROOMS NEEDED

ROOMS Needed	Type of Room	Free/Comp.	Cony. Exp.	Dist. Exp.	Users Exp.
District President	Master Suite	1			
General Convention Manager	Parlor Suite	1			
Contest Administrator	Parlor Suite	1			
Chairman of the Events Committee	Room	1			
Judges	Room		11		
Society Representative	Room		1		
Dist. Production Dir. /Audio-Video Mgr.	Room		2		
Events Team Key Managers	Room		6		
Dedicatee	Room		1		
Board Of Directors	Room			11	
District Committee Chairmen (invited)	Room			5	
Past District Presidents	Room				12
TOTALS	53	4	21	16	12

Table 3.5

2.1.15. Insurance

The Society provides liability insurance for all Society events. It is limited to \$5 million dollars and the General Convention Chairman will furnish a certificate of insurance to the auditorium for its protection. The procedure is to write or phone the Society Office at least 90 days before the convention, giving the auditorium's corporate or legal name and request they be issued a certificate of insurance. There is no charge for this and it will be accomplished for every convention, contest and contest afterglow held in the FWD.

The General Convention Chairman may obtain Cancellation/Catastrophe insurance. The procedure is to phone the Society Office at least 90 days before the convention and they will put you in contact with the current insurance company handling this type of insurance. This coverage is to protect the budgeted income to the District in the event of a catastrophe, requiring the cancellation of the convention and contests. The cost of this insurance is a convention expense and application should be made at least 90 days before the convention.

2.1.16. Judges Services

The Judges Services Chairman is responsible for overseeing the arrangements for the visiting panel of judges. It is the responsibility of the District Representative Contest & Judging (DRCJ) to provide the Judges Services Chairman with a list of Judges. He will provide the necessary information on the number of judges and candidates that will be in the judging area. He will also be responsible for providing and approving expense vouchers for the judges to the General Convention Chairman in accordance with the provisions of the International C&J Handbook (See Exhibit AE-07-SD).

The assigned Contest Administrator will provide to the Judges Services Chairman a list of supplies needed by the Judges and candidates at the contest in writing, at least 60 days before the contest.

The Judges Services Chairman of this committee is responsible for coordinating with the Contest Administrator and Auditorium House Chairman for the needs in the Judging area (as outlined in the Contest and Judging Handbook) and for printing the Scoring Summary after the contests. He is responsible for providing transportation for the judges to and from the airport and between the hotel and the auditorium.

There must be a room (preferably backstage) to which the judges can retire during intermissions. It should be provided with coffee and cold drinks. A buffet lunch for the judges, to be eaten in this room, may be requested, saving considerable time between the morning and afternoon contest sessions. The cost of this luncheon will be at convention expense, however, the individual expense form (CJ-22) will be adjusted accordingly. This should be coordinated with the Contest Administrator.

2.1.17. Licensing

ASCAP/BMI/SESAC licenses are required only for performances to which the general public is invited. If all events are covered by registration, license is not required. If required, however, it is the responsibility of the General Convention Chairman, to arrange for this license with the District Secretary in accordance with Society regulations. The license cost is a convention expense.

2.1.18. Masters Of Ceremonies

The General Convention Chairman nominates (with recommendations from the Events MC Manager) Masters of Ceremonies (MC's) to the Events MC Chairman at least two months prior to the contest for approval. For district conventions/contests the MC nominee's names must appear on the approved MC list provided by the District Events MC Chairman. A different MC should be appointed for each contest session to provide experience for the greatest number of MC's. MC's should be members of the Society or acceptable to the Events MC Manager. They will be briefed by the Contest Administrator, on how to introduce contestants and what obligatory announcements must be made regarding tape recordings, flash pictures, closing of doors, etc.

2.1.19. Medical

Qualified medical personnel in the person of a Medical Doctor (MD) or Registered Nurse (RN) are to be assigned either in the auditorium, or on call, during each convention/contest session. If this is not possible, the information for obtaining medical help should be available in the event of an emergency. Most communities have a 911 emergency service, and therefore, the location of the nearest telephone should be determined. (Cell phones may be used to call 911).

2.1.20. Photography

Photography of the choruses and quartets at the Spring/Divisional Convention is required, however, this service will not be a Convention/Contest expense. The General Convention Chairman arranges for the photographer to provide this service at no cost to the District. The host chapter will furnish a set of risers for use by the photographer and provide an area where the photographs will be taken.

2.1.21. Printing/Graphics

The Printing/Graphics Committee Chairman shall be responsible for printing badges, programs, registration forms, housing forms and flyers. The printing committee shall be responsible for printing programs, registration forms, housing forms and flyers.

Programs are needed for contests. Covers are sometimes available, at no charge, from the local Convention Bureau with a city or area theme. The program should contain a listing of the judging panel (including practice panel) and the MC for each contest session.

The Quartet contestants should be listed with the name of the quartet, chapter(s) represented, members names in the order of tenor, lead, baritone and bass; two blank lines to be provided for the songs they sing.

A page can be left in the back of the program with ten numbered blank lines to list the quartet finalists, announced at the end of the preliminary session.

The Chorus contestants should be listed by Chorus name, director's name, Chorus location & city, and Plateau type with room for their two songs (See Sample AS-14-SD).

The printing and distribution of Official Scoring Summaries is the responsibility of the Judges Services Chairman Committee after release of the original by the Contest Administrator.

2.1.21.1. Signage

The Printing/Graphics Committee also has the responsibility for producing signs that are needed at various locations throughout the Venue.(See Samples AS-15-SD).

2.1.22. Publicity and Public Relations

The Advertising/PR Chairman and members of his committee should prepare articles for *WESTUNES* and see that registration forms and housing forms will appear in at least one issue preceding the convention and on the *FWD Web Site* (www.spebsqsfwd.org). The district quarterly magazine, *WESTUNES* should be utilized whenever possible. There is no charge to the convention for ads in *WESTUNES*.

They should contact the local news media to determine the form and content of items acceptable for release and the time frame in which they work. These materials should be produced on a timely basis and with the input of the Events Marketing/PR Chairman and District Chairman for Music and Performance.

2.1.23. Recording

Videos segments of the archival recording may be provided to each competitor at convention expense. Financial arrangements and licensing agreements for the distribution of videotape of said performances will be made between the contestants and the production company upon the approval of the Chairman of the Events Committee. If "masters" are created, they will become district property and be retained by the District Secretary as part of the District archives and may be made available to the District Representative Contest & Judging. No cost will be borne by the convention for this service. Stringent Federal rules govern performances to the public and must be clearly understood and followed. All other recordings are illegal and will be confiscated unless authorized by the Chairman of the Events Committee. Audio cassette performance recordings will be given to each contestant at each session of the quartet and chorus contest in the Fall contests.

2.1.24. RV (Recreational Vehicles)

The RV (Recreational Vehicle) Chairman shall be responsible for obtaining parking facilities for those individuals who wish to attend the convention while staying in their recreational vehicles. Frequently, hotels are willing to allow the outer edges of their parking lots for this purpose. A fee is normally charged for this parking, which may be used to pay for security if it is deemed necessary. The manager shall prepare publicity to be published in *WESTUNES* and on the *FWD Web Site* (www.spebsqsfwd.org) regarding RV Parking and shall be prepared to assign specific parking places based on the size of the vehicle involved.

2.1.25. Registration

This committee under the Registration Chairman will arrange for registration facilities, (See Exhibit AE-09-SD) in conjunction with the General Convention Chairman, in the headquarters hotel or Auditorium as required throughout the following hours:

Thursday: 7 p.m. to 9 p.m.

Friday 9 a.m. to 11 p.m.

Saturday 9 a.m. to 8 p.m.

The specific duties of the registration committee include: Obtain computer generated badges and holders, registration forms and other supplies necessary to register choruses, quartets and individuals.

1. Process the registration of all individuals, quartets, and choruses attending the convention. District policy states that all persons attending the convention must be registered. The registration package includes a name badge and reserved seat identification for all contest sessions and the Show of Champions. Admission to the afterglow (if used) is by name badge. Food and beverage service may be provided on a no-host basis at no charge to the convention.
2. Provide complimentary pre-registrations for the following:
 - a. Each member of the Official Judging Panel.
 - b. Each candidate or practice judge who has been invited by the District Representative Contest & Judging (DRCJ) to score all practice sessions.
 - c. All assigned Masters of Ceremonies.
 - d. All guests representing the Society Office.
 - e. *WESTUNES* photographer or his representative.
 - f. The Convention Dedicatee (if used)
 - g. Other guests designated by the General Convention Chairman.
3. To facilitate the handling of pre-registration, this committee will:
 - a. Prepare publicity and registration forms for publication in *WESTUNES* to appear in three issues preceding the Convention and on the *FWD Web Site* (www.spebsqsfwd.org).
 - b. Process returned registration forms in the order received, making note of the date received. Prepare name badges. NOTE: In some instances the local convention bureau will type the name badges.
 - c. File information on each registrant, recording name, and method of payment; check number etc., chapter affiliation, auditorium seat assigned. Accurate records shall be maintained and shall be in the possession of the Registration Chairman at the convention in the event a problem arises.
 - d. Encourage competing choruses to pre-order as a block so they might be seated together.
 - e. Provide ribbon streamers for Judges. These are available from the Society Office and must be ordered at least 30 days in advance.
 - f. Provide judges' registration packets to the Contest Administrator by the Convention General Chairman in advance. The CA will be responsible for their dissemination to the panel. All other name badges must be picked up at the registration area at the headquarters hotel.
 - g. Maintain a close working relationship with the Finance Chairman and forward all registration revenue on a continuing and timely basis
4. The following items should be available at the registration area:
 - a. Computer(s), printers or typewriter(s) (large type) and typist.
 - b. Adequate personnel to handle registrations.
 - c. Registration forms and name badges.
 - d. Cash box containing adequate change.
 - e. Completed pre-registration name badges.

- f. Tickets for special events, dinners, and bus transportation if necessary, etc.
- g. Schedules of events and maps showing location of events in the hotel.
- h. List of restaurants, shopping centers, etc.
- i. Telephone (optional) and/location of the nearest public telephone.
- j. First Aid Kit.

2.1.24.1 Registration - Cost

The cost of a registration for Spring/Divisional Conventions shall be **\$40.00**, 30 days before the convention start date. A late charge of **\$10.00** will be assessed each registrant after that date. The cost of a registration for youth under 26 shall be one half the adult registration fees. Registrations are **transferable** but **not refundable**.

2.1.25.2. Reserved Seating

Seats for all sessions of the International Quartet Preliminary contests and Show Of Champions will be reserved. Open seating is established for the Divisional chorus, quartet sessions and the High School contests. The information from Exhibit AE-11-SD will be strictly followed.

2.1.25.3. Patron Registration.

The pre-registration procedures for **patrons and contestants** are generally carried in the district magazine *WESTUNES*, various competitor direct mailings, and on the **FWD Web Site** (www.spebsqsafwd.org). It should be recognized that all participants of a Convention/Contest must take special actions. The FWD Statement Of Policy clearly identifies the several levels of registration, the individuals that are exempt from cost for registration and costs for each. In short, a contestant must also **register** to attend the convention as well as additionally **enter** to compete (two separate forms posted to two different recipients). Contact man of the quartet or chorus generally handles the latter. But registration for the convention alone does not carry with it registration for competition and vice versa. Special arrangements are provided for selling of individual registrations to the general public, if seating is available, prior to the start of the event, Note, however, **all contestants must hold a Full Registration.**

2.1.26. Schedule, Overall

The contests are conducted in accordance with the current C&J Rules, which specify tasks and responsibilities of the Contest Administrator and other contest personnel.

2.1.26.1. General Schedule.

The detailed schedules for the Convention/Contests will be found in (Part D, Section 2). This part of the manual is only available on the Convention Manual CD and FWD Web Page in Word & Excel format. Typical of these are: AF-200-F Schedule of Events and AF-201 & 202-F Schedule for Competition/Show. The FWD Fifteen Year calendar (Spring/Divisional dates) can be found in (Part B, Section 3)

2.1.27. Security

Special arrangements must be made for security in the auditorium, parking lots, RV Parking and housing locales. Hotels normally provide the latter; however, arranging for security at the other sites is the responsibility of the Convention/Contest Security Committee. This committee will arrange for police and fire protection as necessary.

2.1.28. Transportation

This committee is necessary if there is a need for patron transportation between the headquarters hotel(s) and the contest site. The cost for bus rental and the number of buses required are part of the convention bid and that expense is figured into the budget. A bus pass may be sold by the Special Events Committee at the Registration Desk, in the form of a ticket or a sticker, to be affixed to the registrant's convention badge.

The Judges Services Coordinator will provide for transportation for the judging panel wherever required.

-End of Spring/Divisional General Info -

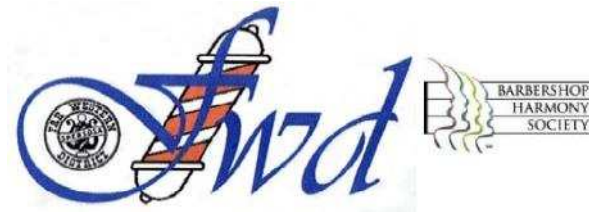

**BARBERSHOP HARMONY SOCIETY
SPEBSQSA, INC.**

FAR WESTERN DISTRICT

**PART B - SECTION 1
SPRING/DIVISIONAL
CONVENTIONS/CONTESTS
TASKS/JOBS/TIMELINES**

**GENERAL
CHAIRMAN**

JTE-01-SD



GENERAL CONVENTION CHAIRMAN (GCC) (FWD SPRING/DIVISIONAL CONVENTIONS) JOB DESCRIPTION AND TIMELINES

Duties and Responsibilities:

Because the job of the General Convention Chairman is the key position in all of the FWD Convention/Contests, additional descriptive material is provided in this section. The General Convention Chairman is responsible to the FWD President through the Chairman of the Events Committee for a successful convention. The General Convention Chairman works with the Chairman of the Events Committee and follows the Convention Regulations, which reflect District Policy.

He prepares and submits the Contest Bid and updates the budgets, in conjunction with the Finance Manager, and is responsible for all expenditures. He must see that all timetables are adhered to and results reported in a timely manner.

He must approve and sign all reports and ensure that the final report is submitted within the time limit prescribed by these regulations and the District Statement Of Policy (SOP). He schedules timely meetings for the entire committee (general), and as needed with specialized committees. A published schedule of date, location and time for each general meeting will be furnished each Committee Chairman, District President, and Chairman of the Events Committee.

He arranges for VIP preferential housing at the headquarters hotel and seating for all contest sessions through the Events Housing Manager. VIP's are defined as FWD Board members, judging panel, past district presidents, AFWDC members, FWD committee chairmen, members of the House of Delegates, Hall of Fame members, FWD chapter coaches, FWD judges, Events managers and invited guests (International Representative etc.) as identified by the Chairman of the Events Committee.

The General Convention Chairman has the final responsibility on behalf of the chapter for insuring a successful convention. He must delegate authority and is responsible for all committee activities.

**Note: Administrative FORMS (Excel)
Are only available on the Convention Manual CD
and FWD Web Site (www.spebsqsafwd.org).**



FWD SPRING/DIVISIONAL CONVENTION OPERATIONAL SCHEDULE

The Spring/Divisional Convention/Contests timeline schedule has been created over many years of FWD Convention/Contests. It should serve as a guide to the General Convention Chairman charged with the successful implementation of his respective duties. The schedules are provided in checklist form. The checklist covers the pre-contest period from more than two years in advance to the actual date.

Task Timeline GENERAL CONVENTION CHAIRMAN

Task	Target Date	Completed Date	Person Assigned
MORE THAN THREE (3) YEARS IN ADVANCE			
' Obtain Bid Package which includes bid forms from CEC (Form AF-100-SD).			
' Appoint General Convention Chairman (GCC).			
' Secure letter of agreement for hotel and meeting rooms.			
' Secure letter of agreement for auditorium.			
' Prepare preliminary budget (Form AF-101x-SD).			
' Present bid to CEC.			
' Copy CEC, DVP and DP on all correspondence.			
AFTER RECEIVING THE BID			
' Contract for auditorium.			
' Contract for hotel and meeting room(s) if needed..			
' Notify the Convention Bureau and/or hotels that you have receive the bid.			
ONE YEAR IN ADVANCE			
' The General Convention Chairman and the Finance Chairman prepare a Revised Budget (Form AF-102x-SD) for submission to the CEC for the subsequent FWD Board of Directors meeting.			
' Contract with hotels for confirmation of price of rooms.			
' Contract with transportation company (if needed).			
' Appoint Committee Chairmen and provide them with a copy of the Convention Regulations pertaining to each of their duties.			
' Copy CEC, DVP, and DP on all correspondence.			

Task Timeline

GENERAL CHAIRMAN

Task	Target Date	Completed Date	Person Assigned
EIGHT MONTHS IN ADVANCE			
' The Graphics committee must meet with the GCC or CEC to lay out its plans for printing flyer/registration forms, programs, forms, etc.			
' Send proofs of all items to be printed to CEC for approval.			
' Registrations flyer/forms printed for distribution.			
' Prepare registration flyer/form for Westunes and FWD Web Page.			
SIX MONTHS IN ADVANCE			
' Hold General planning meeting with entire committee.			
' Special Events committee should make arrangements for any event scheduled including golf tournament at local golf course (if you are having one).			
' Publicity and Public Relations Committee should prepare an article for WESTUNES.			
' Begin computer program for Registrations.			
THREE (3) MONTHS IN ADVANCE			
' The GCC shall arrange with the Society for the Certificate of Liability insurance for both the contest and the afterglow.			
' The PR Committee should start local publicity. This committee should also present the chapter presidents and secretary with convention information.			
' The Registration Committee should procure name badge blanks and holders from the Convention Bureau if available or from local office supply dealers.			
' The DRCJ sends a list of the judges and candidate judges who will be in the judging area to the GCC. The Contest Administrator will send a list of the supplies that will be needed.			
' The General Convention Chairman sends to the DRJC Form CJ-21: "Information For Computing Expense Allowance Required For Official Panel Members" (Exhibit AE-07) This information is needed by the DRJC to determine the actual costs and expense of the judging panel on Form CJ-22 (Exhibit AE-07).			

Task Timeline

GENERAL CHAIRMAN

Task	Target Date	Completed Date	Person Assigned
TWO (2) MONTHS IN ADVANCE			
‘ Conduct a Convention Committee meeting including CEC.			
‘ The Auditorium Stage Committee should secure the shells (if being used) for the chorus contest and monitor speakers for the quartet contests.			
‘ The GCC should be advised of staging information so that the competitors can be informed and quality production will result. Make arrangements for any additional stage-related equipment and/or labor.			
‘ GCC or Awards Chairman will contact and coordinate with the FWD Events Awards Mgr. To obtain convention competition awards and traveling trophies.			
‘ The GCC must report to the CEC the status of registrations and expenses to budget. All competing choruses not reported registered at this time should be contacted by email or telephone.			
‘ The GCC must submit the names of the Masters of Ceremonies to FWD Events MC Mgr. (Advise using names from approved MC list but not required).			
ONE (1) MONTH IN ADVANCE			
‘ The GCM conducts draw for Choruses and Quartets.			
‘ General Convention Committee Meeting with the CEC.			
‘ The Auditorium House Committee should make arrangements for badge checkers, and/or door monitors.			
‘ Quartets and Choruses should be assigned a host and the Host Chairman sends via email, Convention Packet with information about where the competitors should be times and how to get there.			
‘ GCC/Awards Chairman should have all traveling trophies and awards on hand as previously identified by the FWD Events Awards Mgr.			
‘ The Registration Chairman should double-check all registrations, against printed name badges.			
‘ The DRJC sends the GCC completed CJ-22 Forms for each judge on the official panel. These will contain housing and other information regarding the judging panel.			
‘ The GCC and Finance Chairman finalized expense from CJ-22 Forms and sends each judge his per-diem check for room/meals/travel expenses.			

Task Timeline

GENERAL CHAIRMAN

Task	Target Date	Completed Date	Person Assigned
TWO (2) WEEKS IN ADVANCE			
' Host Chairman should have made contact with all Quartet and Chorus and followed up as necessary.			
' All arrangements should have been made with TV, Radio, for coverage of special events by quartets, etc.			
' Transportation needs confirmed.			
TEN (10) DAYS IN ADVANCE			
' Print Program.			
' Registration Committee updates all materials, prepares name badges, etc.			
' Hosts Chairman makes final contact with Quartets/Choruses.			
' Awards and Traveling Trophy's are all secured.			
' House Committee obtains all materials asked for by the Contest Administrator.			
FRIDAY AND DAY OF CONVENTION			
' Judges Service Chairman/committee members pick up Contest Administrator and all judges at airport.			
' Check all accommodations of judges.			
' Escort Contest Administrator to Auditorium for walk-through.			
' House Crew available for set-up of Judging area.			
' GCC delivers badges, programs, etc. to all Judges in judge's room.			
' Introduce all MC's to Contest Administrator.			
' Introduce mike-testing quartet to Contest Administrator for mike-test.			
' Registration Booth is set up and manned, and everything is running smoothly.			
WITHIN ONE (1) MONTH AFTER CONVENTION			
' Pay all outstanding bills.			
' Finalize accounting and prepare the Final Statement, Form AF-103x-SD.			
' Hold follow-up meeting with entire Convention Committee.			
' Send Final Statement (no later than 45 days) to FWD Treasurer (along with check) with copies of statement to CEC, DEP, DP and District Board.			
' Send thank you letters to CA, Committee Chairmen, Hotel, Auditorium, Etc.			



**BARBERSHOP HARMONY SOCIETY
SPEBSQSA, INC.**

FAR WESTERN DISTRICT

**PART B - SECTION 2
SPRING/DIVISIONAL
CONVENTIONS/CONTESTS
JOBS/TIMELINES**

**COMMITTEE
CHAIRMEN**

JTE-05-SD



**AUDITORIUM "STAGE" COMMITTEE CHAIRMAN
(FWD SPRING/DIVISIONAL CONVENTIONS)
(INCLUDES THE SECURITY SUB-COMMITTEE)
JOB DESCRIPTIONS AND TIMELINE**

Duties and Responsibilities:

The manager of this committee is in charge of the building "behind the footlights". This includes the stage, lighting, sound, curtains, dressing rooms, etc. He will need several good helpers backstage to pre-set the stage. The use of two-way radio hand sets for communications has proven to be extremely beneficial in the smooth handling of backstage traffic. He should work closely with the District Production Director and Monitor/Movement Manager.

The District Production Director/Stage Manager normally is the person that calls all lighting, audio, curtain and on-stage movement cues to the control booth for a smooth transition from one presentation to another.

This committee is responsible for procuring and setting up suitable choral shells (if being used) for use by the choruses and up to eleven sections of four step risers for the choruses. The determination of how many riser sections is made by the DRCJ after communication with each competing chorus representative. Shells are not required for quartets; monitor speakers must be used instead.

No one will be allowed backstage without specific approval of the General Convention Manager or the Production Director. Personnel should be appointed to keep backstage traffic to a minimum. Effort should be made to conform to the stage, curtain and riser configuration specified by the Society Office and used in International Competition.

The Security Committee will arrange for police/security and fire protection as necessary. It is advisable that a physician or registered nurse be on the premises. This person could be a member attending the convention. His/her seat number and availability should be ascertained. If this is not possible, the information for emergency medical help should be available in the event of emergency. The nearest telephone or cell phone should be secured.

The Auditorium Stage Manager assigns dressing room, warm-up rooms etc., makes all arrangements with the Monitor/Movement Manager for the proper flow of contestants from dressing rooms, to warm-up rooms, to backstage, to on-stage, to off-stage, to photographer, to dressing rooms.

Task Timeline Next Page

AUDITORIUM STAGE TASK TIMELINE

Task Timeline

(Includes the Security Sub-committee Timeline)

Task	To be done	Completed
‘ Appoint Stage Manager	One year prior to convention	
‘ Obtain location and usability of choral shells (if used).	Six months prior to convention	
‘ Get commitment from chapters for use of risers on stage, warm-up rooms, photo area etc	Six months prior to convention	
‘ Find location of rental of radio communications.	Three months prior to convention	
‘ Walk through of all workers.	Week of convention or Sat. morning	
‘ Rent radio communications devices.	Friday of convention week	
‘ Pre-set stage with risers and shells.	Friday morning	
‘ Breakdown of risers and shells.	Saturday evening after show.	
‘ Return of all rental and borrowed equipment.	Monday after convention	



**AWARDS COMMITTEE CHAIRMAN
 (FWD SPRING/DIVISIONAL CONVENTIONS)
 JOB DESCRIPTIONS AND TIMELINE**

Duties and Responsibilities:

The General Convention Chairman or a person appointed by him is in charge of securing all pertinent traveling trophies and corresponding with the FWD Awards Chairman who will furnish all other awards. The awards will be secured from the FWD Events Awards Manager and placed backstage for presentation to recipients. An inventory of awards and trophies will be given to the GCC or Stage Manager, backstage.

SPRING /DIVISIONAL CONVENTION/CONTESTS COMPETITION AWARDS

DIVISIONAL CONVENTION/CONTESTS COMPETITION AWARDS

DIVISION Competition Awards	Type/ Traveling Trophy	Type/ Plaque	Type/ Certificate
Chorus Champions	Traveling Trophy	1-Plaque	
Top Scoring Plateau A Chorus		1-Plaque	
Top Scoring Plateau AA Chorus		1-Plaque	
Top Scoring Plateau AAA Chorus		1-Plaque	
Most Improved Chorus	Traveling Trophy	1-Plaque	
Quartet Champions	Traveling Trophy	4-Plaques	
High School Quartets	law High School Policy		
Novice Quartet		4-Plaques	
College (as applicable)	None	None	
TOTALS	3	13	None

Table 2.2

Task Timeline

AWARDS COMMITTEE TIMELINE

Task	To be done	Completed
‘ Correspond with FWD Events Awards Mgr.	Three months prior to convention	
‘ Locate and make arrangements for return of all traveling trophies.	Three months prior to convention.	
‘ If Events Awards Manager is unable to obtain awards, you must order all awards as per Events Manager's instructions. All plaques will be made of oak color backing with burnished surface containing the following in sequence: District Logo, Division, recipient, e.g. (Division Chorus Champion), location of contest and year.	Three months prior to convention.	
‘ Secure all traveling trophies.	Week of convention	
‘ Written inventory of awards and trophies.	Saturday morning	



**FINANCE COMMITTEE CHAIRMAN
 (FWD SPRING/DIVISIONAL CONVENTIONS)
 JOB DESCRIPTIONS AND TIMELINE**

Duties and Responsibilities:

The Finance Chairman prepares a budget Form AF-101x-SD, in conjunction with the General Convention Chairman, for convention income and expenses, which is submitted with the original bid form. He is responsible for the accurate accounting of all receipts and expenditures. He is also responsible for preparing a revised budget Form AF-102x-SD for submission to the CEC for the board meeting prior to the convention.

Separate banking records, apart from normal chapter finances, shall be established for the duration of the convention,

Send checks of final accounting Form CJ-22 (AE-07-SD) to each Judge thirty days prior to the contest for expenses, including meals, accommodations and travel.

NOTE: The General Convention Chairman must submit to the District Treasurer, with copies to the CEC, DEP, FWD President and the FWD Board of Directors, a fully detailed statement of income and expenses, Form AF-103x-SD.

This statement must be accompanied by a check made payable to the Far Western District, covering the District's share within **forty-five days** of the completion of the convention. If this is not accomplished, a penalty is levied in which the District's share shall increase by one percent for each week the report is late.

The host chapter should preserve all financial records of the convention for a period of **ten years**. It is highly recommended that the Finance Chairman work closely with the Registration Manager.

Task Timeline

FINANCE COMMITTEE TIMELINE

Task	To be done	Completed
‘ Prepare preliminary budget form AF-101x-SD.	At least two years prior to Conv.	
‘ Set up separate Convention Accounting Records.	One year prior to convention	
‘ Prepare revised budget, form AF-102x-SD, with GCM.	One month prior to Fall Conv.	
‘ Make out and mail checks to judges.	Thirty days before convention	
‘ Pay hotel bills.	Sunday of convention	
‘ Finalize and pay any auditorium bills.	Within one week of convention	
‘ Provide Final Statement AF-103x-SD & Check.	Less than 45 days after convention	
‘ Preserve all records and receipts.	Ten years after conventions	

JTE-08-SD



**GRAPHICS/PRINTING COMMITTEE CHAIRMAN
(FWD SPRING/DIVISIONAL CONVENTIONS)
JOB DESCRIPTION AND TIMELINE**

Duties and Responsibilities:

The Graphics Chairman must be efficient with computer graphics and may appoint others with similar talent to assist in these tasks. His committee is responsible for gathering all the information need for designing (following Convention Manual guidelines) and printing of the convention registration badges, registration forms, flyers, program, signage any other graphically designed items needed by the convention. Printing of the program is too large a project and he must make arrangements with a local printer for reproduction. Printing of the Contest Score Sheets is the responsibility of the Judges Services Chairman. The Graphics Chairman works closely with all the committee chairmen that need assistance with graphics and printing.

The layout samples for the Flyer/Registration, Badges and Program can be found in Adm. Samples (AS-01-SD through AS-16-SD) One program is used for the entire convention, broken down into Four (4) sections as follows:

Part 1. Pertinent information regarding the convention: general schedule of events, welcome message, list of judging panel, committee managers, etc.

Part 2. Quartet contest information:

- a. MC's Name
- b. Mike-testing quartet
- c. Name of each competing quartet
- d. Chapter(s) represented
- e. Members names in order of: Tenor, Lead, Baritone and Bass
- f. Two blank lines for songs they will sing

Part 3. Chorus contest information

- a. MC's name
- b. Mike-testing chorus
- c. Chorus Name
- d. Director(s) name(s)
- e. Chapter name and location (city/state)
- f. Plateau and Division
- g. Two blank lines for songs they will sing

Part 4. Show of Champions information:

- a. MC's name
- d. 3rd and 2nd place quartets
- e. Quartet Champions
- f. Chorus Champions
- g. Final group songs

Task Timeline next page

Task Timeline

GRAPHICS/PRINTING COMMITTEE TIMELINE

Task	To Be Done	Completed
' Prepare registration forms, registration badges, flyer/ad, etc.	(8) Months prior to convention	
' Get all information from the GCC and DRJC.	(8) Months prior to convention	
' Send proofs of registration forms, and flyers to CEC for approval.	(7) Months prior to convention	
' Print registration forms, housing forms, and flyers.	(6) Months prior to convention	
' Pre-Print Badges with background information if desired.	(3) Months prior to convention.	
' Layout Program for proofing.	(2) Months prior to convention	
' Prepare and Print all Signage for Convention.	(2) Weeks prior to convention	
' Finalize layout and print Program.(after receipt of draw list).	(2) Weeks prior to convention	



**HOUSING COMMITTEE CHAIRMAN
 (FWD SPRING/DIVISIONAL CONVENTIONS)
 JOB DESCRIPTIONS AND TIMELINE**

Duties and Responsibilities:

The chairman of this committee is responsible for maintaining control of room assignments, ensuring that VIP's are assigned to rooms in the headquarters hotel as directed by the CEC. If more than one hotel is used, he appoints an individual to be the host chapter's representative to each hotel, serving as a liaison in the event there are problems with room assignments. The CEC will furnish a copy of the rooms that will be booked in advance and paid for by the district. All other VIP blocked rooms will be released 90 days prior to the start of the convention if not booked.

He serves as the Society's and District's good will representative to the hotel staff and works closely with the hotel manager and night managers to eliminate any possible misunderstanding regarding the late night singing by convention attendees.

A pre-convention meeting must be held with the CEC, GCM, Housing Manager, and all hotel staff within the week prior to the convention. A checklist should include confirming check-in and check-out times, peek meal times, for extra service help, physical separation of our convention registrants from general guest of the hotel. Preplan your identification (badge or I.D. card) so that you are recognizable to key staff people.

The Housing Manager works very closely with the CEC (Chairman of the Events Committee) as many of the jobs that need to be done in advance are originated and assigned by him.

SPRING/DIVISIONAL CONVENTION/CONTESTS HOTEL ROOMS NEEDED (50 approx.)

SPRING/DIVISIONAL CONVENTION Sleeping Rooms Needed	Free/ Complimentary	Convention Expense	District Expense	User's Expense
District President	1 Master Suite			
General Convention Manager	1 Parlor Suite			
Contest Administrator	1 Parlor Suite			
Chairman of the Events Committee	1 Room			
Judges		10 Rooms		
Society Representative		1 Room		
District Production Director/Audio-Video Manager		2 Room		
Dedicatee		1 Room		
Events Team Key Managers		6 Room		
Current District Quartet Champs.		2 Rooms		
Board Of Directors			11 Rooms	
District Committee Chairman (invited)			5 Rooms	
Past District Presidents				12 Rooms
Total Rooms 54	4	22	16	12

Table 2..6

Task Timeline Next Page

Task Timeline

HOUSING COMMITTEE TIMELINE

Task	To Be Done	Completed
' Prepare Housing Form for Graphics Chairman.	(6) Six months prior to convention	
' Book rooms for Judging Panel, Convention Committee Chairmen, Etc.	(6) As received but not later than Six months prior to convention	
' Book Room for Afterglow at Hotel if one is planned.	(6) Six months prior to convention.	
' Make arrangements for RV Parking at Headquarters Hotel or close RV Park.	(6) Six months prior to convention.	
' Make list of signage for hotel.	(4) Four months prior to convention	
' Set up final GCC meeting with hotel staff.	Week of convention	
' Send letter of thanks to Hotel.	Within one week following convention	

JTE-11-SD



**JUDGES SERVICES COMMITTEE CHAIRMAN
(FWD SPRING/DIVISIONAL CONVENTIONS)
JOB DESCRIPTION AND TIMELINE**

Duties and Responsibilities:

The Judges Services Chairman of this committee is responsible for coordinating with the Contest Administrator and Auditorium House Chairman for the needs in the Judging area (as outlined in the Contest and Judging Handbook) and for Printing the Scoring Summary after each contest. He is responsible for providing transportation for the judges to and from the airport and between the hotel and the auditorium. It is advisable to contact the FWD Events Judges Services Manager to make sure all avenues are covered before the convention starts.

There must be a room backstage or close by to which the judges can gather and retire during intermissions. It should be provided with coffee, tea, and cold drinks. It is permissible to cater a buffet lunch for the judges, to be eaten in this room, saving considerable time between the morning and afternoon contest sessions. This should be coordinated with the Contest Administrator.

Coordinate with the House Chairman to have people available to move tables and help with the set-up of the Judging area (Exhibit AE-06-SD) Friday evening or Saturday morning. Tables, chairs, lectern with light, two (2) long extension cords, at least two separate power lines and paper are needed at all contests (items are in traveling storage container, check for availability). Bottled water, pencils, mints/etc. for each judges' area are required. Contest Administrator will furnish a list of items and layout of judge's area.

DRCJ will furnish a list of judges and the Contest Administrator to the General Convention Chairman. The GCC will contact the Contest Administrator for his instructions for set-up etc. and pass the information on the Judges Services Chairman.

The Judges Services Chairman or his assigned designee must be available to the Contest administrator at all times during the convention. He must take final Score Sheet Masters for printing after each contest session. After printing is completed, distribute copies at the auditorium, hotel and dressing area. He must furnish the CA with copies for his files upon his return.

Task Timeline Next Page

Task Timeline

JUDGES SERVICES COMMITTEE TIMELINE

Task	To Be Done	Completed
‘ Contact Contest administrator for instructions.	Three months prior to convention	
‘ Locate printer for printing score sheets.	Three months prior to convention	
‘ Locate Convention Traveling Storage Container and make arrangements for delivery to contest site.	Three months prior to convention	
‘ Coordinate transportation pick-up of judges.	Two months prior to convention for airport- to- hotel, hotel-to- auditorium, etc.	
‘ If printing score sheets yourself, get paper.	Week of convention 8 1/2 x 11 three (3) colors	
‘ Set-up judges area with help from House Committee.	Saturday morning	
‘ Bring ream of white 8 1/2 x 11 paper and two dozen #2 pencils for CA.	Day of contest	
‘ Set up refreshment table in judges' room backstage.	Saturday afternoon and evening	
‘ Cater lunch for judges in backstage room (if planned).	Saturday afternoon (coordinate with CA)	
‘ Pick up final score sheet masters from CA. Take to printer and deliver for distribution throughout auditorium, afterglow and hotels.	After each contest	
‘ Transport judges from hotel to airport.	Sunday of convention	



**MEETINGS COMMITTEE CHAIRMAN
 (FWD SPRING/DIVISIONAL CONVENTIONS)
 JOB DESCRIPTION AND TIMELINE**

Duties and Responsibilities:

The Meeting Managers responsibilities are to work with the Convention General Manager in succoring all the meeting rooms in advance of the convention at the Headquarters Hotel. He must meet with the Hotel Catering Manager with all the requirements for each meeting room, in example, start and end time, number of attendees, layout of room, food./drink requirements, person in charge of each room, etc. Exhibits for District board meeting and House of Delegates meeting layouts should be given to person in charge of room set-up.

He must work closely with the District Secretary to make sure that any late minute changes in times or the catering manager will meet layout requirement.

SPRING/DIVISIONAL CONVENTION/CONTEST MEETINGS

SPRING/DIVISIONAL Meetings	Days	Seating	Setup
FWD Board	Thursday 2:00 p.m.	Conference style (10 only) Guests (50) theater style See Exhibit N	Coffee Water/Tea Soft Drinks
House of Delegates	Friday 2-5 p.m.	See Part 5.0. Exhibit C Guests: (50) theater style at back of room. Room should accommodate 150	Water
Chapter Coaches	As scheduled	Conference style	Water
Contest Evaluations	DVP C&J Schedule	As arranged by the CA	Coffee/Water/Tea
Youth Activities	As Arranged	50 Theatre Style	Water
PROBE	As Arranged	25 Theatre Style	Water
Chorus Dir. Guild	As scheduled	Conference Style	Coffee/Water/Tea
AH=Sow	As arranged	As arranged	Water
High School Glow	As Scheduled	As arranged by DVP Youth	Water Station
Ladies Hospitality	As Scheduled	25 As Arranged	Coffee/Water/Tea
Events Postmortem	Sunday 10:00 a.m.	25 Conference Style	Coffee/Water/Tea

Task Timeline Next Page

Task Timeline

MEETINGS COMMITTEE TIMELINE

Task	To Be Done	Completed
' Meetings Manager appoints committee.	One year prior to convention.	
' Secures all rooms needed for meetings.	One year prior to convention.	
' Checks on any extra rooms or dropped meetings.	Six months prior to convention.	
' Meets with Hotel Catering Mgr.	Week of convention.	
' Makes final changes or additions.	Week of convention.	
' Helps with set up of Board meeting room	Thursday afternoon.	
' Helps with set up of H.O.D. meeting room	Friday morning.	
' Checks on all remaining meeting rooms.	Friday through Sunday.	
' Attend Events wrap-up meeting.	Sunday morning.	
' Checks Hotel bills for meeting room charges.	Sunday morning.	

JTE-13-SD



**MONITOR (MOVEMENT) COMMITTEE CHAIRMAN
 (FWD SPRING/DIVISIONAL CONVENTIONS)
 JOB DESCRIPTIONS AND TIMELINE**

Duties and Responsibilities:

The Chairman of this committee is in charge of the flow of competing quartets, choruses and anyone that will be participating in the stage area. "Behind the footlights". He will need to appoint several key people who will be assigned two ways radio handsets for communications between each other. Several runners are needed to keep the quartets and choruses lined up and ready to go on stage at the proper time. The Monitor/Movement Chairman works closely with the Production Director/Stage Manager and Host Chairman.

This Chairman is responsible for producing a Monitor/Movement Workers Schedule with the help of the General Convention Chairman, Stage Manager, Host Chairman and the Contest Administrator. Strict guidelines and time frames are to be followed as per Convention Relations. These time schedules are to be given to the Host Chairman for distribution to all competitors.

The Traffic Schedule for Awards and Show of Champions are to be given to all participants as soon as possible after each contest to keep confusion to a minimum back stage. The Stage Manager will follow these Schedules.

Task Timeline

MOVEMENT (MONITOR) TASK TIMELINE

Task	To be done	Completed
' Appoint, Traffic/Movement Chairman	One year prior to convention.	
' Assign jobs to each person on committee.	One year prior to convention.	
' Make copies of Exhibit Movement Schedule Forms.	Six months prior to convention.	
' Finalize Movement Schedule Forms	Immediately after draw.	
' Distribute Movement Schedules to Host Chairman, etc.	Day after draw.	
' Set up Traffic/Movement table in dressing area.	Morning of convention.	
' Meeting with Host Chairman and Host Committee.	Morning of convention.	
' Pick up communications equip. and check if working.	Morning of convention.	
' Return all communications equipment to Stage Mgr.	After Show of Champions.	

JTE-14-SD



**PHOTOGRAPHY/AUDIO/VIDEO COMMITTEE CHAIRMAN
 (FWD SPRING/DIVISIONAL CONVENTIONS)
 JOB DESCRIPTION AND TIMELINE**

Duties and Responsibilities:

The Chairman and his committee are to help set up the area for photography of contestants and assist the photographer with all his needs. Get application forms, costs etc. from photographer and, if possible, send to contestants in advance. Keep in contact after convention to see that proofs are sent to contestants in a timely manner.

The Recording Committee will produce performance CD recordings that will be given to each contestant, at convention expense, at each session of the quartet and chorus contest. CD's will be delivered to the contest administrator after each session to be distributed to the contestants. No copies may be made from these recordings.

Video production of the contests must be approved by the CEC and, if provided, will be at no cost to the convention. If video production will take place, location of cameras cannot be in the judging area. The contest administrator/stage manager must approve the location for video cameras. The video Production Company must obtain all reproduction rights, licenses and permission and pay all fees. Proof of reproduction rights must be given to the GCC in advance. Costs of video DVD's are not acceptable as a convention expense and all licensing, distribution, etc., will be the obligation by the Production Company. A minimal costs may be recovered from the competitors choosing to purchase the tapes. No reproduction of videotapes is permitted without express permission of the video production company.

Task Timeline PHOTOGRAPHY/AUDIO/VIDEO COMMITTEE TIMELINE

Task	To Be Done	Completed
' General Convention Chairman appoints Committee.	Six months prior to convention	
' General Convention Chairman hires a photographer.	Six months to a year before Conv.	
' He appoints a CD machine operator if required.	Six months to a year before Conv.	
' Purchase audio CD's for quartet/chorus performances.	Week of convention	
' Committee helps set up photo area risers if required.	Saturday morning	
' Deliver CD's to Contest Administrator.	Immediately after each contest	



JTE-15-SD
PUBLICITY/PUBLIC RELATIONS COMMITTEE CHAIRMAN
(FWD SPRING/DIVISIONAL CONVENTIONS)
JOB DESCRIPTION AND TIMELINE

Duties and Responsibilities:

This Chairman and members of this committee should prepare articles for *WESTUNES* and see that registration forms and housing forms will appear in three issues preceding the convention. There is no charge to the convention for ads in *WESTUNES*. Prepare Registration Forms for FWD Web Page also.

They should contact the news media to determine the form and content of items acceptable for release and the time frame in which to work. These materials should be produced on a timely basis and with the input of the CEC.

Task Timeline PUBLICITY AND PUBLIC RELATIONS COMMITTEE TIMELINE

Task	To Be Done	Completed
‘ People to contact for Publicity: a. TV/CABLE stations b. Newspapers large and small c. Radio stations both AM and especially FM d. Magazines e. Business Bulletins (members) f. Senior Newspapers and Magazines g. Local retail businesses h. Mall Associations i. High Schools and Colleges in the area j. Organizations and clubs k. Churches/Synagogues etc.	One year up to day of convention	
‘ Write press releases and articles.	One year up to day of convention	

JTE-16-SD



**REGISTRATION COMMITTEE CHAIRMAN
(FWD SPRING/DIVISIONAL CONVENTIONS)
JOB DESCRIPTION AND TIMELINE**

Duties and Responsibilities:

This committee will arrange for registration facilities (registration area layout Exhibit R), in conjunction with the General Convention Manager in the headquarters hotel or auditorium, as required, throughout the following hours:

Thursday 7 a.m. to 9 p.m.

Friday 9 a.m. to 11 p.m.

Saturday 9 a.m. to 8 p.m.

The Registration Manager will procure computer-generated badges, registration forms and other supplies needed to register choruses, quartets and individuals attending the convention.

Process the registration of all individuals, quartets and choruses attending the convention. Everyone attending the convention must be registered, including individuals purchasing specific events registrations only.

The full registration package includes the following:

Name badge

- a. Admission to all contests and Show Of Champions
- b. Admission to the afterglow, (if one is provided). by name badge.
Food and beverage service if provided, will require an additional charge.

File information on each individuals registration, recording:

- a. Date received
- b. Name
- c. Method of payment
- d. Check number etc.
- e. Chapter affiliation
- f. Type of registration
- g. Voice part.

Accurate records shall be maintained and shall be in the possession of the Registration Manager at the convention in the event a problem arises.

The Contest Administrator will be responsible for the judges registration packets and will coordinate this with the General Convention Manager.

All registrations must be picked up in person and at the Registration Desk.

ALL REGISTRATIONS including single events must be accompanied by a registration form and may be purchased in the Registration area designated for that purpose. All late registrations (within 30 days of convention) will be charged a late fee. No refunds are provided, however exchanges are permitted.

All competing members must purchase a **SPRING/DIVISIONAL REGISTRATION**.

Maintain a close working relationship with the Finance Manager and forward all registration funds to the Finance Manager on a continuing and timely basis.

Appoint committee member to contact all Disabled people responding as such on the registration form. He must make sure that all special needs are provided for prior to the convention.

Provide complimentary pre-registrations for the following:

- | | |
|---|--|
| a. Each member of the Official Judging Panel | d. Convention Dedicatee and spouse. |
| b. Each candidate or practice-scoring judge who has been invited by the DRCJ to score ALL contest sessions. | e. All guest representing the Society Office |
| c. All assigned Masters of Ceremonies | f. <i>WESTUNES</i> photographer or his representative (2 total). |
| | g. Other guests approved by the CEC or DP. |

With the help of the Graphics and PR Mgr's prepare an advertisement and publicity for the *WESTUNES* magazine including registration forms and hotel registration forms. These advertisements to appear in three issues preceding the convention. (Exhibit AS-01-SD). Prepare registration forms for FWD Web Page.

The following items should be available at the Registration area at the convention:

- a. Computer or Typewriter (large type)
- b. Adequate personnel to handle registrations
- c. Registration forms and badges.
- d. Cash box containing adequate change.
- f. Computer readout of pre-registrations.
- g. Everyone must sign for registration packets.
- h. Tickets for special events, dinners, bus, etc.
- h. Extra schedule of events, list of hospitality rooms, maps showing location of events, etc.
- j. Telephone or cell available.
- k. First Aid Kit

Task Timeline

REGISTRATION COMMITTEE TIMELINE

Task	To Be Done	Completed
' Prepare advertisement for <i>WESTUNES</i> .	Six months prior to convention	
' Prepare Registration Form for FWD Web Page.	Six months prior to convention.	
' Late charge starts for all registrations.	Thirty days prior to convention	
' Committee meeting to run through plans.	Week before convention	
' Give GCC Badges, Programs, Etc. for judges.	Day of the convention	
' Set up registration facilities in headquarters hotel or auditorium.	Thursday 7 p.m. to 11 p.m. Friday 9 a.m. to 11 p.m. Saturday 9 a.m. to 8 p.m.	
' Individuals must pick up their own registration badges.	At registration area.	



**RV PARKING COMMITTEE CHAIRMAN
 (FWD SPRING/DIVISIONAL CONVENTIONS)
 JOB DESCRIPTIONS AND TIMELINE**

Duties and Responsibilities::

The RV (Recreational Vehicle) Manager shall be responsible for obtaining parking facilities for those individuals who wish to attend the convention while staying in their recreational vehicles. Frequently, hotels are willing to allow the outer edges of their parking lots for this purpose. A fee is normally charged for this parking, which may be used to pay for security if it is deemed necessary. Always check city ordinance on RV Parking. When RV parking is not available at the Hotel or Auditorium, find the nearest locations of any RV Parks in the area. Inform those parks and set up a program for reserving space for participants. The Manager shall prepare publicity to be published in *WESTUNES* regarding RV Parking and shall be prepared to assign specific parking places based on the size of the vehicle involved.

Reserved parking places must be set-aside for judges, Sound Company if used, etc. Each should be notified of their availability. Reserved parking, maps and directions for Chapters Trailers with risers, etc. to load and unload at auditorium Personnel for directing, unloading and loading of equipment etc.

Task Timeline **RV PARKING COMMITTEE TIMELINE**

Task	To Be Done	Completed
‘ Meeting with hotel and location of area for RV Parking.	One year in advance of convention	
‘ Check city ordinance on RV Parking.	One year in advance of convention	
‘ Inform local RV Parks of people coming.	One year in advance of convention	
‘ Article for <i>WESTUNES</i> on RV Parking.	Five months prior to convention	
‘ Pre-register the RV people.	Five months prior to convention	
‘ Arrange for Security in RV parking area.	Five months prior to convention	
‘ Collect fees and assign parking to late people.	Weekend of convention	

JTE-18-SD



**CONVENTION SECRETARY/COMMUNICATIONS CHAIRMAN
 (FWD SPRING/DIVISIONAL CONVENTIONS)
 JOB DESCRIPTION AND TIMELINE**

Duties and Responsibilities:

The Convention Secretary keeps the minutes of all meetings and acts as a repository for convention records and correspondence. He writes in conjunction with the General Convention Chairman and submits all required reports.

Makes sure that he receives a copy of any correspondence, contracts, etc. from anyone concerned with the convention and keeps in accessible files.

He sends copies of all meeting notes, correspondence and reports to the appropriate people such as District President, CEC, etc.

Submits reports on all activities and correspondence sent and received at each General Convention Meeting.

Task Timeline

SECRETARY, COMMUNICATIONS TIMELINE

Task	To Be Done	Completed
' Attends all meetings and keeps minutes of meeting.	From acceptance of bid to after Convention	
' Keeps records and maintains correspondence.	Entire existence of Convention Committee	
' Submits reports to Convention Committees.	Each General Convention Committee meeting	
' Submits reports to District personnel.	Within one week of meeting	



**SIGNAGE COMMITTEE CHAIRMAN
(FWD SPRING/DIVISIONAL CONVENTIONS)
JOB DESCRIPTION AND TIMELINE**

Duties and Responsibilities:

The General Chairman may appoint a Signage person, who will work closely with all committees and make signs for any occasions where needed especially at Registration Area, Parking, Auditorium, etc. Use a computer to generate signs to save money. Signs will be needed for the following:

- a. Registration area, box identification etc.
- b. Large overhead signs for prices, instructions, hosts etc.
- c. Direction to all events
- d. Individual quartet and chorus names
- f. Parking directions
- g. Billboard directions for public
- h. Non-singing areas of hotel

Task Timeline Next Page

SIGNS NEEDED

Task	Completed
<p>Some of The following signs are needed because of District Policy of having registration badges with you at all times. Others are just plain courtesy on your part as host. Check with GCC to see if he has any special signs that may be needed.</p>	
‘ REGISTRATION AREA (A-D, E-H etc.) - One for each station, check with registration person on how many people he will be using.	
‘ SIGN-IN TABLE FOR QUARTETS AND CHAPTER REPS. - A table should be set up by the contestant dressing area where quartets and chapter reps. should sign-in and get information where dressing area is, time sheets etc.	
‘ QUARTET AND CHORUS DRESSING AREA - One sign for each competing quartet and chorus to be located on door or in area to dress.	
‘ JUDGES ROOM - One sign to be put on judges room door.	
‘ NO SEATING BEYOND THIS AREA (where applicable) - One or two signs for blocked off area behind judges pit (one row of seats) or first row.	
‘ NO TALKING BEYOND THIS POINT - Make up at least 2 of these signs for outside and inside of stage door.	
‘ WARM-UP ROOM	
‘ READY ROOM	
‘ ALL CONTESTANTS MUST HAVE REGISTRATION BADGES WITH THEM AT ALL TIMES. Make up at least 2 of these signs for the dressing area.	
‘ PLEASE SHOW REGISTRATION BADGE BEFORE ENTERING STAGE. - Make up one sign for outside of entrance to stage.	
‘ NO ONE WILL BE ALLOWED IN AUDITORIUM WITHOUT REGISTRATION BADGE – Make up one sign for lobby area or for each entrance door into auditorium.	
‘ QUARTET AND CHORUS CONTACT SIGN-IN TABLE - Make up one sign for lobby area and one for dress room area.	

Task Timeline

SIGNAGE COMMITTEE TIMELINE

Task	To Be Done	Completed
‘ Check with hotel on where and how signs can be used. Coordinate with GCC.	Six months prior to convention	
‘ Get list of signs needed from each committee Chairman.	Three months prior to convention	
‘ Prepare all signs.	One month prior to convention	
‘ Distribute signs for placement.	Day of convention	

JTE-20-SD



**SPECIAL EVENTS COMMITTEE CHAIRMAN
(FWD SPRING/DIVISIONAL CONVENTIONS)
JOB DESCRIPTION AND TIMELINE**

Duties and Responsibilities:

The Special Events Chairman works closely with the FWD Convention Activities Chairman and is responsible for planning additional activities to entertain visitors when contest sessions are not being presented. These usually take the form of a golf tournaments, tours to interesting places in the area, ladies hospitality activities, special Barbershop Seminars, etc. These events are not mandatory but tend to leave a nice feeling about your city in the minds of the visitors.

Events that require a payment of some sort should be kept to a minimum. A tournament may require an entry fee, which pays for the prizes and use of the facility. There will be no cost to the convention for any special event.

Check with quartets and choruses coming to conventions to see if they would be available to do PR at local hospitals, rest homes, malls, schools, etc.

If the host chapter wishes to sell merchandise such as patches, shirts, cups etc., there shall be no cost to the convention. Approval for sale of articles must be obtained from CEC in advance.

Task Timeline

SPECIALS EVENTS COMMITTEE TIMELINE

Task	To Be Done	Completed
' Set up tours, etc.	One year in advance of convention	
' Work with Publicity Chairman for PR.	Six months prior to convention	
' Check with GCC or DEP on rooms for Ladies Hospitality, etc.	Six months prior to convention	
' Set up schedule for quartet/chorus appearances.	Six months prior to convention	
' Contact TV and Radio Stations on appearances.	One month prior to convention	

JTE-21-SD



**TRANSPORTATION COMMITTEE CHAIRMAN
(FWD SPRING/DIVISIONAL CONVENTIONS)
JOB DESCRIPTION AND TIMELINE**

Duties and Responsibilities:

This committee is necessary if there is need for transportation between the headquarters hotel(s) and the contest site. The cost for bus rental and the number of buses required are part of the convention bid and that expense is figured into the budget. The Special Events Committee at the Registration Desk in the form of a ticket or a sticker to be affixed to the registrant's convention badge may sell a bus pass.

This Transportation Manager is responsible to see that buses are available at the headquarters hotel to transport the registrants to the contest site on a rotating basis. The number of buses should be kept to a minimum. The Chairman shall be available to see that this task is conducted in a reasonable manner from the hotel, and likewise, from the contest site back to the hotel after the completion of the contest session.

Check on all available bus service in the area for the best prices. Try and get the cost of bus time to just the hours that the busses will be needed.

Task Timeline

TRANSPORTATION COMMITTEE TIMELINE

Task	To Be Done	Completed
' Contact bus services for rates etc.	Three years in advance for Bid	
' Sign contracts for bus use at convention.	Six months prior to convention	
' Set up schedule and supervise all busses.	Day of convention	



**BARBERSHOP HARMONY SOCIETY
SPEBSQSA, Inc.**

FAR WESTERN DISTRICT

**PART B - SECTION 3
SPRING/DIVISIONAL
CONVENTIONS/CONTESTS
ADMINISTRATIVE
EXHIBITS**

AE-01-SD rev Apr 10, 2013



**FAR WESTERN DISTRICT
BARBERSHOP HARMONY SOCIETY**

**FIFTEEN-YEAR CALENDAR 2013-2027
FWD DISTRICT SPRING (INT. PRELIMS)**

YEAR	WEEKEND MARCH	CONVENTION LOCATION	CLOSE CONV. SAI - REG.11	CLOSE CONV. SAI - REG.12	CLOSE CONV. SAI - REG. 21	HOLIDAY EASTER	HOLIDAY PASSOVER	REMARKS
2013	March 21-24		March 14-17		March 26- April 02	March 31	March 26- April 02	
2014	March 20-23		March 27-30		April 15-22	April 20	April 15-22	
2015	March 19-22		March 26-29		Apr 04-11	April 05	April 04-11	
2016	March 10-13		March 17-20		April 23-30	March 27	April 23-30	
2017	March 16-19		March 23-26		April 11-18	April 16	April 11-18	
2018	March 15-18				March 31- April 07	April 01	March 31- April 07	
2019	March 21-24				April 20-27	April 21	April 20-27	
2020	March 19-22				April 09-16	April 12	April 09-16	
2021	March 18-21				March 28- April 04	April 04	March 28- April 04	
2022	March 17-20				April 16-23	April 17	April 16-23	
2023	March 16-19				April 06-13	April 09	April 06-13	
2024	March 14-17					March 31	April 23-30	
2025	March 13-16					April 20	April 13-20	
2026	March 12-15					April 05	April 02-09	
2027	March 18-21					March 28	April 22-29	

NOTE: Future Division Contests combined with the Spring Convention will be awarded at a later date (dates may change)
Rev. Apr 2013 jj

AE-02-SD



**FAR WESTERN DISTRICT
BARBERSHOP HARMONY SOCIETY**

2010 BID MANUAL

SPRING INT. QUARTET PRELIMS/DIVISIONAL CONVENTION/CONTESTS

FORWARD

This Manual has been prepared to assist FWD chapters and convention bureaus in evaluating:

1. The ability of a chapter, chapters, and its members to organize, manage and successfully host a FWD Spring Int. Quartet Prelims/Divisional Convention/Contests.
2. The availability of adequate, desirable and affordable facilities in the prospective host city.

An inquiry to host a FWD Spring Int. Prelims/Divisional Convention/Contests may originate from a chapter, a group of chapters, or by a city that is interested in hosting this convention but which does not have a local chapter. The FWD Events Committee could act as the host committee in the event there is not a chapter in the Host City. The bid must be submitted on the official bid form provided by the FWD CEC (Chairman of the Events Committee) or FWD Convention Manual Administrator Fritz Grunewald at:

FWDConvManual@aol.com

In seeking out desirable FWD Spring Int. Prelims/Divisional Convention locations, the FWD CEC (Chairman of the Events Committee) contacts, or is sometimes contacted by, convention bureaus and/or hotels. Such inquiries are reviewed for basic convention requirement. If applicable, they are then discussed with a local FWD Society chapter contacts for consideration.

FWD Barbershop Harmony Society conventions rely heavily on local volunteers to handle many details of planning and the overall convention operation. Chapters interested in bidding for a FWD Spring Int. Prelims/Divisional Convention should first obtain a pledge of support from the chapter members. Included in the following pages is information pertaining to basic convention requirements, recommended procedures and organizational guidelines. Also included is a copy of the official FWD Spring Int. Prelims/Divisional Convention Bid and Budget forms. This material should answer most of your questions. However, if you need additional information, feel free to contact your Division VP or current FWD Chairman of the Events Committee.

John Jones

2010 FWD Chairman Events Committee

johnkathyjones@aol.com

RECOMMENDED STEPS FOR A CHAPTER CONSIDERING A FWD BARBERSHOP HARMONY SOCIETY SPRING INT. PRELIMS/DIVISIONAL CONVENTION BID

1. Review carefully and thoroughly the Manual of Requirements (extra copies are available on request from FWD Convention Manual Administrator Fritz Grunenwald at "FWDConvManual@aol.com").
2. Discuss the basic requirements at the chapter Board of Directors meeting:
 - a. Do the chapter members enthusiastically support the idea of hosting a FWD Fall Convention?
 - b. Does your city have adequate existing facilities and attractions as required and outlined in the Manual of Requirements? (Auditorium, convention bureau, hotel rooms, parking facilities, special interest activities, etc.)
 - c. Are these facilities available on the specified dates?
3. If the chapter Board of Directors votes favorably on extending a convention bid, an acting General Chairman should be designated to coordinate arrangements, through the convention bureau, for the specified dates to be *tentatively* reserved at the hotels and the auditorium.
4. Next, the President, or someone appointed by him, should be requested to present this matter to the chapter membership at a regular (or perhaps a specially called meeting of the entire chapter membership for this specific purpose) chapter meeting.
5. Host chapters are expected to investigate and assist in arranging for those events that will create unique convention experience for the attendees.

SUBMITTING THE BID

If the decision is to proceed with the bid, complete the Official Bid Form CA-100-SD in triplicate, and the other required supporting documents, sending one complete set to the FW CEC (Chairman of the Events Committee) one copy to your Division VP and retain the other for your records.

SITE SELECTION PROCESS

Once the bid is received by the FWD CEC (Chairman of the Events Committee) a site visit is scheduled by the local DEP (Division Events Planner) etc. This generally is a one-day visit to the city where a thorough inspection of all of the proposed facilities is conducted. Subsequently, a report of these findings is prepared and distributed to the FWD CEC (Chairman of the Events Committee) for review. He then prepares a list of any specific concerns he may have and sends it to the applicable bidding city/chapter for resolution.

It is expected that the FWD CEC (Chairman of the Events Committee) will meet at the Spring or Fall Convention and will discuss all bids. It is at this meeting that the selection will be made as to which cities will be recommended to the FWD Board of Directors. This recommendation is presented to the FWD House of Delegates for ratification.

The selection criteria that the committee will use as the basis of its recommendation are:

1. Accessibility- air service, travel considerations.
2. Affordability- proposed hotel rates, transportation to and from the city, cost of meals, local transportation, etc.
3. Attractiveness- attractive winter destination; attractions, tours, vacation desirability, reputation of the city.
- 4 Facilities- proposed contest venue, functionality of hotels for our needs, moving attendees between hotels and contest venue.

CONVENTION MANAGEMENT

The organization of the FWD Spring Int. Prelims/Divisional Conventions is controlled by the FWD CEC (Chairman of the Events Committee) subject to the authority of the District Board of Directors on policy matters.

Convention plans made by the local General Chairman and his committee are to be reviewed by the local DEP. The direct supervision of the Sprint Int. Prelims/Divisional Convention is the responsibility of the FWD CEC (Chairman of the Events Committee). The Convention Steering Committee should be comprised of the following people:

General Chairman
Assistant Chairman
Secretary
Treasurer
One (1) or two (2) committee coordinators
Local DEP

This committee formulates the overall plan for the convention and establishes policy within the framework as set forth by the FWD CEC (Chairman of the Events Committee). In general terms, the CEC is responsible for the operation of the convention and the General Manager is responsible for the supervision of the committees and their assigned duties.

FINANCES

The host chapter(s) receives the following share of convention income or flat fee:

1. (30% maximum) of the net proceeds (Spring Int. Prelims/Divisional and Fall)
(Chapter Run – 2008-2009)
2. (\$1,500 Spring Int. Prelims/Divisional) (FWD Events Team Run)

The FWD shall retain all other convention revenue from all other sources unless prior approval by the CEC is given. All budgeted and approved expenses of the convention, including publicity, steering committee expenses, registration materials, staff travel and expenses, etc. are paid through the Convention Finance Chairman.

Budgeted items that are considered amenities (those not essential to the operation of the convention) and proposed by the host chapter(s) are the sole responsibility of the host chapter(s). Examples would be gifts for Judges and/or their wives; committee uniforms; hospitality rooms; special services such as limo service from the airport for selected dignitaries, etc. The cost of these items, if paid for by the FWD, will be deducted from the host's share at the time of the budget reconciliation.

STEERING COMMITTEE PERSONNEL

Following is a list of steering committee personnel normally required and a summary of the general qualifications and duties involved:

General Chairman Must be an organizer, a topnotch leader, well liked, highly respected and devoted to the Society. Secretarial help and unlimited use of telephone facilities are essential. Must be available on very short notice to handle convention business.

It is the responsibility of the General Chairman to select qualified committee chairmen to assist him with the convention planning and operations. Personal follow up on contracts with local officials, hotels, the convention bureau, etc., is required. He must not be afraid to replace a committee chairman who is not doing his job.

Assistant Manager The Assistant Chairman must have the same qualifications as the General Chairman. This man must be in a position to relieve the General Chairman by assuming supervision of details and should be intimately acquainted with all convention arrangements in order to assume the responsibilities of the General Chairman should it become necessary. He may also be responsible for special assignments given to him by the General .

Secretary Keeps minutes of Steering Committee meetings and general meetings. Maintains committee convention records and correspondence on the local level.

Finance Chairman Acts as the financial officer of the convention on the local level. Prepares the initial Convention **Preliminary Budget Form CA-101-SD** and subsequent **Revised Budget Form CA-102-SD** when due, to the FWD CEC (Chairman of the Events Committee). Pays vouchers and invoices submitted by committee chairmen (after approval by the General Manager). Amounts not specifically identified in the budget and all items **over \$100** must be approved by the FWD CEC (Chairman of the Events Committee). Advances may be made to the host chapter so that no chapter funds are used for convention expenses.

Reimbursements of out-of-pocket convention related expenses, are made to committee chairmen by the convention Finance Mgr. on presentation of receipts and paid invoices, which have been approved for payment by the General Chairman, the Finance Chairman also receives all monies collected by the host chapter or its designees, from the public registration sales and sales of special event registrations.

These funds are to be deposited in a special Fall Convention account. A final accounting of all transactions handled by the Finance Chairman (income and expense **Form CA-103-SD**) is to be sent to the **FWD Treasurer (along with check)** and copy of the form to the FWD CEC (Chairman of the Events Committee), and FWD President

Within 45 days following the close of the convention.

The host chapter(s) and the FWD Events Committee share a solemn obligation to meet or exceed the estimated profit figure as indicated in the approved convention budget.

The Society office provides liability and property damage insurance coverage for the convention at no cost to the chapter.

Fundamental Requirement of the Host Chapter

1. Provide adequate volunteer personnel (from one or more chapters). A minimum of 20 active members is required full time during the convention.
2. Provide an adequate number of volunteers (from one or more chapters) to fill the principal committee assignments of the convention.
3. Actively support the convention effort through member participation and promotion.

-End of Document-

AE-03-SD

**BARBERSHOP HARMONY SOCIETY
 FWD SPRING/SUMMER/FALL MEETINGS
 BOARD OF DIRECTORS MEETING SEATING PLAN**

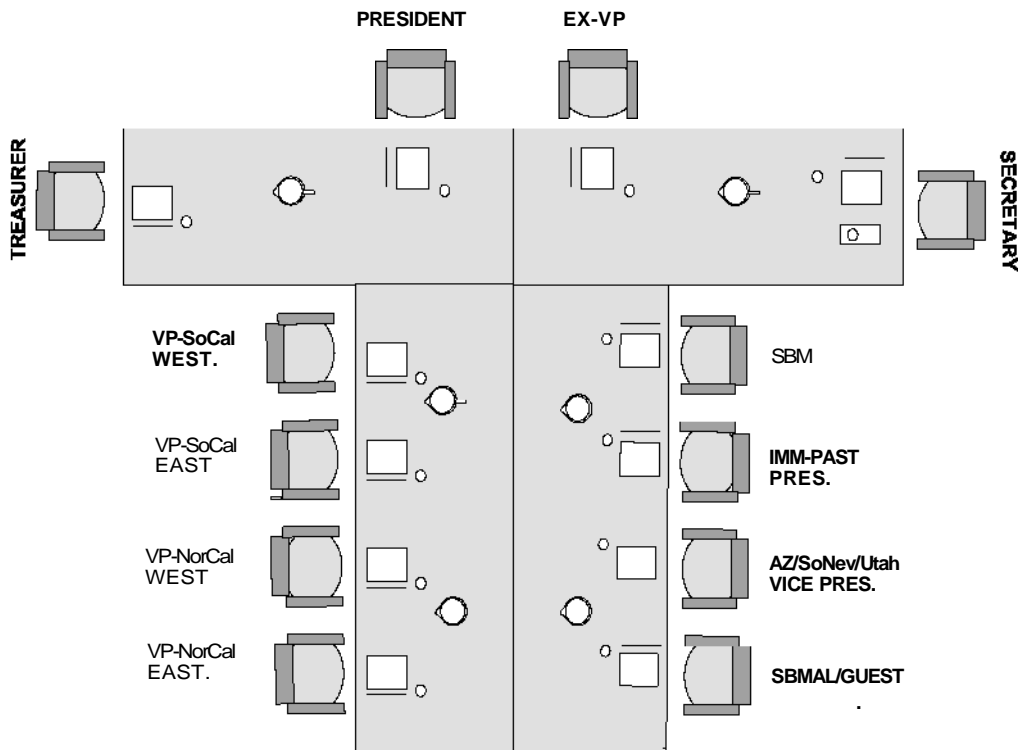

GUESTS SEATING AREA

1. Thursday afternoon 2:00 p.m.
 Friday morning 8:30-12 noon (if required)
2. All tables should be draped.
3. Water and glasses on table
4. Refreshment table in back (both days)
 Water, Coffee, Tea, Soft Drinks, no ash trays
5. Seating-Board, Conference Style (12 only)
6. Seating-Guests, Theater Style (50) in rear

AE-04-SD



**FAR WESTERN DISTRICT
BARBERSHOP HARMONY SOCIETY**

2010

**SCHEDULE OF PAYMENTS
FOR CHAPTER HOST**

FOR-HIRE PAY FOR WORK

FWD Spring/Div.	\$1,500.00
FWD Fall	\$4,500.00
SW Div.	\$ 500.00
SE Div.	\$ 500.00
NW Div.	\$ 500.00
NE Div.	\$ 500.00
ARIZONA Div.	\$ 500.00

FWD Board Meeting June 10, 2006. Motion 4. To modify the current policy to provide that the chapters hosting divisional conventions be guaranteed \$800 against the 50/50 split and that the “chapter for hire” to be paid \$500. (MSP)

AE-05-SD

**BARBERSHOP HARMONY SOCIETY
 FWD SPRING/FALL CONVENTIONS
 HOUSE OF DELEGATES SEATING PLAN**

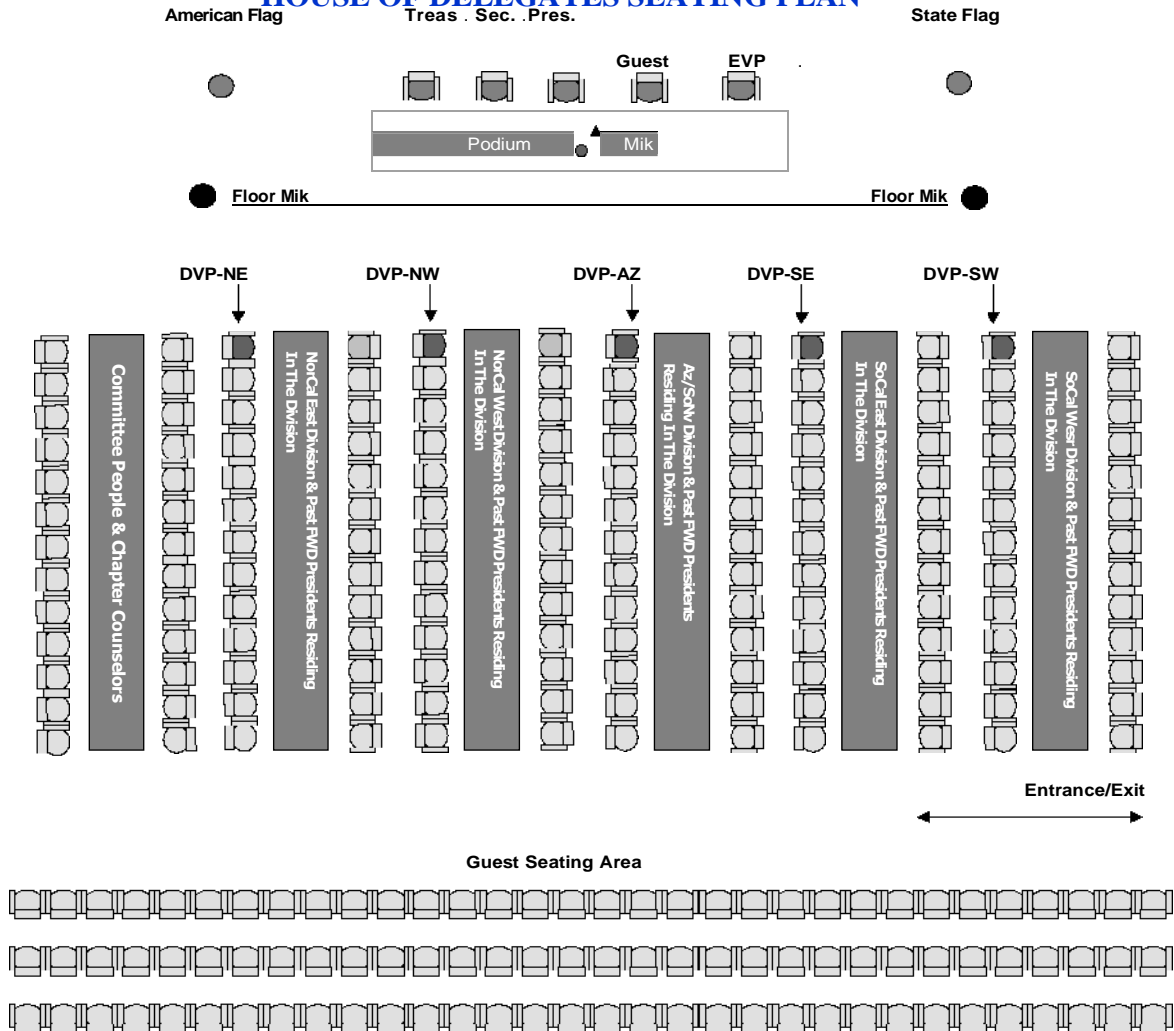

1. All tables should be draped.
2. Water and glasses at each table.
3. HOD members to be seated at tables.
4. Guest seating in chairs at the rear. (50)

AE-06-SD



FWD BARBERSHOP HARMONY SOCIETY
CONTESTS - JUDGING AREA CONFIGURATION

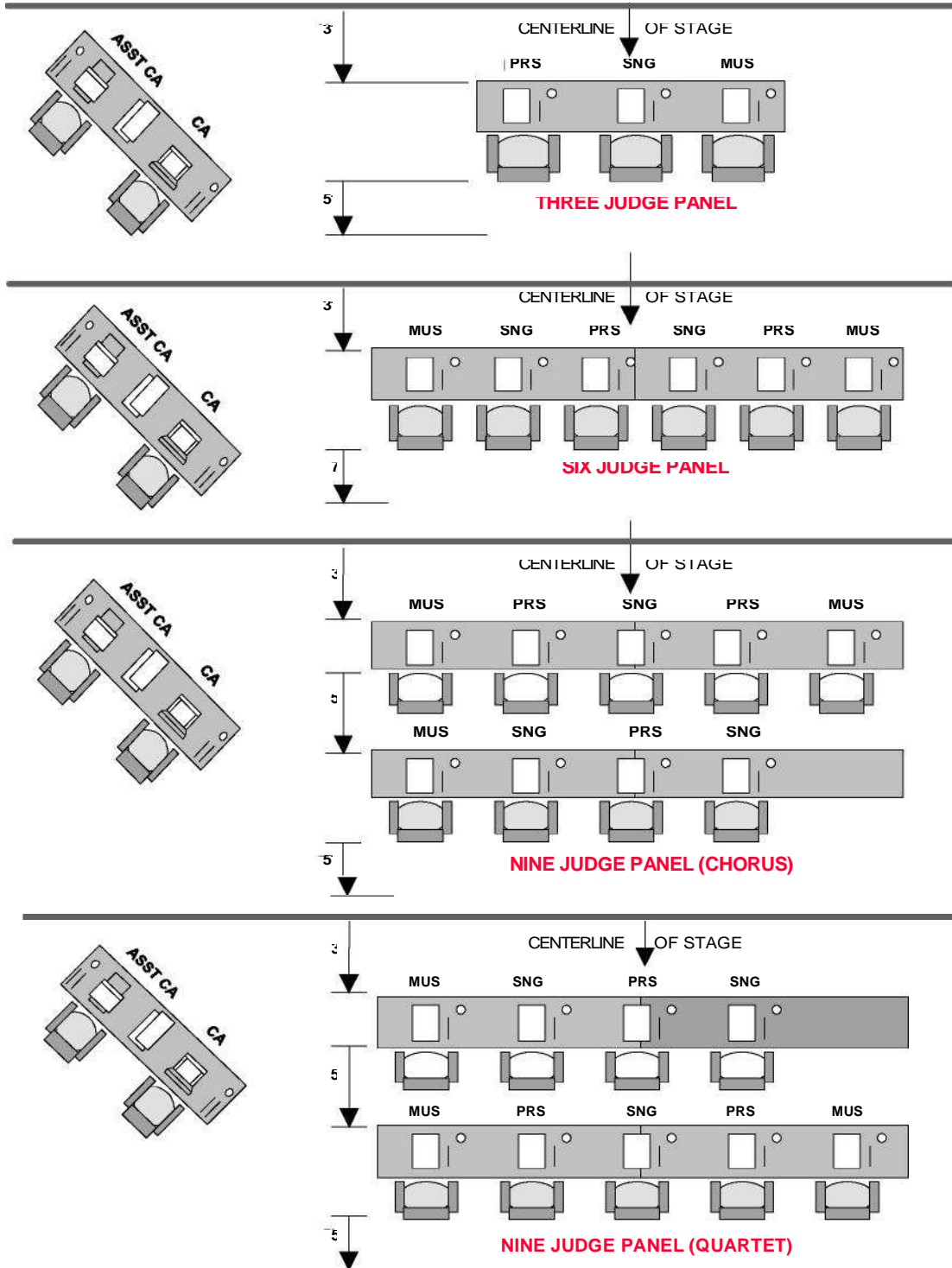

AE-07-SD



This form is only to be used when the contestant is UNABLE to access the Society website and the contest entry procedure there.

CONTEST ENTRY FORM (CJ-20)
Barbershop Harmony Society

Complete both sides of this form as well as the Song Selection sheet(s). For entry into all district and international preliminary contests, this form "must be received by the District Representative Contest and Judging at least 14 days prior to the contest date."

[Article II.B.2. of the BHS Contest Rules; emphasis added]

Check the appropriate boxes below for your quartet or chorus:

QUARTET _____ VLQ _____ CHORUS _____

International _____ International Prelim _____ District _____ Division _____

Please enter _____ in the above-indicated contest to be held _____
[Name of competitor] [Date]

at _____ QUARTET OR CHAPTER NUMBER:
[Location]

The quartet/chorus, in return for authorization to enter the above-indicated contest:

1. Certifies that we have read and agree to abide by the current BHS Contest Rules. We understand that ineligibility will be a consequence for violation of any statement under Article I or II of said rules.
2. Quartet: Certifies that we are members in good standing of one or more chapters of BHS, and at least one member of the quartet is a member of the district in which the quartet has chosen to compete and represent for the current year. Our quartet is duly registered with the Society's headquarters. Our registration expires on _____.
3. Chorus / VLQ: Certifies that our chapter is good standing with the Society and our district, and that all members of the competing chorus are members in good standing of the Society and the chapter they represent.
4. Certifies that each member of the quartet/chorus holds, or will hold, a convention registration for said contest.
5. Certifies that we have complied with copyright law in the acquisition and learning of our contest songs/arrangements. We understand that ineligibility will be a consequence for violation of this statement.
6. Seniors Quartet: Certifies that as of the day of the next international seniors quartet contest each member of the quartet will be age 55 or older and the sum of the quartet members accumulated ages will equal or exceed 240 years.
7. Agrees to record at the convention site two or more songs or medleys for any district/international quartet/chorus album.
8. Agrees that the division or district may record our portion of the contest for division or district archives and use, including **training material to be used in educational programs for Society members.**

FOR INTERNATIONAL CONTESTS ONLY:

9. Agrees to the public exhibition on one or more occasions of motion picture films or a television program or programs using live broadcasts, video tapes, or films, or a combination of two or more of these, which will be made of us and other quartets and/or choruses during the international convention. We agree that all revenues received by the Society, or any of its affiliates, for same may be retained by the Society or affiliate.
10. Agrees that the Society may record our portion of the contest for Society archives and Society use. Included in this agreement is permission to the Society to use available segments of our portion of the contest on recordings to be manufactured and sold by the Society.
11. Agrees to pose for an official picture as scheduled in the convention program

Contest Entry Form, *(continued)*

Song Selection

(List all cleared songs you possibly may use in the contest;
use as many additional sheets as necessary.)

Song 1 (title): _____

Words/Music (lyricist/composer):

Copyright date: _____

Copyright owner(s): _____

Arranger(s): _____

Date of arrangement: _____

Stock # (published/unpublished acquired from BHS Harmony Marketplace):

- or -

Date of legal acquisition from copyright owner: _____

Date of legal acquisition is when you either received permission from the copyright owner (in the case of an individual who owns the copyright) or when you purchased the legal number of copies of a song owned by a publisher that was not acquired through Harmony Marketplace.

Is this song a medley? _____ Yes _____ No

[If yes, ensure that you enter information for each song in medley.]

* * * * *

Song 2 (title): _____

Words/Music (lyricist/composer):

Copyright date: _____

Copyright owner(s): _____

Arranger(s): _____

Date of arrangement: _____

Stock # (published/unpublished acquired from BHS Harmony Marketplace): _____

- or -

Date of legal acquisition from copyright owner: _____

Date of legal acquisition is when you either received permission from the copyright owner (in the case of an individual who owns the copyright) or when you purchased the legal number of copies of a song owned by a publisher that was not acquired through Harmony Marketplace.

Is this song a medley? _____ Yes _____ No

[If yes, ensure that you enter information for each song in medley.]

Contest Entry Form, (*continued*)

* * * * *

Song (title): _____

Words/Music (lyricist/composer): _____

Copyright date: _____

Copyright owner(s): _____

Arranger(s): _____

Date of arrangement: _____

Stock # (published/unpublished acquired from BHS Harmony Marketplace):

- or -

Date of legal acquisition from copyright owner: _____

Date of legal acquisition is when you either received permission from the copyright owner (in the case of an individual who owns the copyright) or when you purchased the legal number of copies of a song owned by a publisher that was not acquired through Harmony Marketplace.

Is this song a medley? ____ Yes ____ No
[If yes, ensure that you enter information for each song in medley.]

* * * * *

Song (title): _____

Words/Music (lyricist/composer):

Copyright date: _____

Copyright owner(s): _____

Arranger(s): _____

Date of arrangement: _____

Stock # (published/unpublished acquired from BHS Harmony Marketplace): _____

- or -

Date of legal acquisition from copyright owner: _____

Date of legal acquisition is when you either received permission from the copyright owner (in the case of an individual who owns the copyright) or when you purchased the legal number of copies of a song owned by a publisher that was not acquired through Harmony Marketplace.

Is this song a medley? ____ Yes ____ No
[If yes, ensure that you enter information for each song in medley.]

AE-07B-SD



**INFORMATION FOR COMPUTING EXPENSE
ALLOWANCE FOR OFFICIAL PANEL MEMBERS CJ-21**

This form is supplied by the DRCJ to the convention chairman ten weeks in advance of the contest date. The convention chairman completes the form in duplicate, retains one copy, and returns the other copy to the DRCJ *at least eight weeks before the contest date.*

Contest: _____ Dates: From _____ to _____

Day and time of first official activity for panel: _____

Day and time of last official activity for panel: _____

Headquarters hotel/motel: _____ Phone: (____) _____

Address: _____

Alternate lodging for panel as agreed upon between DRCJ and convention chairman, if different from above:

Address: _____ Phone: (____) _____

Contest hall address: _____ Phone: (____) _____

Conv Gen Chairman: _____ Home Phone: (____) _____ E-mail _____

Judges Service Chair: _____ Home Phone: (____) _____ E-mail _____

Direct billing for airfares? No Yes Agency _____ Phone: (____) _____

I. Lodging expense

Determine guaranteed twin bed room rate at place indicated above, including all room charges, taxes, etc. \$ _____

Determine guaranteed single room rate, including all room charges, taxes, etc. \$ _____

Will the rooms be prepaid by you? Yes No

II. Meal expenses paid for by the convention

_____	_____	_____
_____	_____	_____
_____	_____	_____

Standard Procedure for Determining Expense Allowance for Members of Contest Panel CJ-21

A. All district administrations and panel members are expected to follow these rules, which apply to official panels at the division, district, and international levels. Application of these rules to other contests is purely a matter between the panel members selected and those in charge of the contests.

B. The expense allowance for members of judging panels should be an equitable sum of money to cover prudent median expenses for panel members serving at contests. The expense allowance is not intended to result in either hardship or monetary gain to the panel member. It is the responsibility of the District Representative Contest and Judging (DRCJ) to approve only that expense allowance that he considers prudent, fair, and equitable.

C. Panel members eligible for expense allowance consist of official scoring panel members, contest administrators, and practice panel administrators (so long as there are sufficient practice panel members and the PPA is not receiving training credit for the service). A panel member who is attending the convention as an official other than a panel member shall not receive duplicate expenses. The DRCJ determines the eligibility of a practice panel administrator and a panel member who is attending as an official.

D. Ten weeks prior to the contest, the DRCJ will send two copies of Form CJ-21 to the convention general chairman. That chairman will complete the forms, retain a copy, and return the original to the DRCJ at least eight weeks prior to the contest date.

E. At least eight weeks prior to the contest date, the DRCJ will send three copies of Form CJ-22 to each panel member, who will fill out items I, II, III, and return all three copies to the DRCJ within five days of receipt. Using the information on Forms CJ-21 and CJ-22, the DRCJ will finish completing Form CJ-22. A panel member may request and use any type of accommodation that is available, but expense allowance will be determined by the DRCJ in accordance with district policy regarding single or shared rooms. At least five weeks prior to the contest, the DRCJ will send all three completed copies of Form CJ-22 to the convention general chairman, who approves them and sends advance checks to the panel members with one copy of Form CJ-22. The convention general chairman retains another copy of the form, and sends the third copy to the DRCJ at least one week prior to the contest. In the event that agreement cannot be reached between the convention general chairman and the DRCJ, the convention general chairman will pay the expenses determined by the DRCJ and may exercise his right to petition the chairman of the Society Contest & Judging Committee within 30 days following the contest for a final ruling on expenses allowed.

F. In the event that the panel member can use less expensive transportation, or is forced to use more expensive transportation, he will contact the DRCJ at the contest site and request the filing of a new CJ-22, which will indicate the true amount of money spent for transportation. The panel member will refund the amount due to the DRCJ, or receive the amount due after the DRCJ has contacted the convention general chairman for a settlement.

G. Registration fees at contests will be gratis to members of the official panel and practice panel members as authorized by the DRCJ.

H. Admission tickets to convention sessions will be furnished gratis, or passes furnished, to the official and practice panel members only if the DRCJ expects their attendance; otherwise, the panel member may or may not purchase a ticket according to his wish.

I. If there is a dispute as to the number of miles between cities, the mileage shown in the latest "Household Goods Carrier Bureau Mileage Guide" plus 10% will be used. This guide is used by most moving companies and reference to it is easy and conclusive. The additional 10% will permit use of more convenient, though longer routes.



TOTAL ALLOWABLE EXPENSES FOR OFFICIAL PANEL MEMBERS CJ-22

To the panel member: complete this side only of this form and return it to the DRCJ *within five days*. Speedy turnaround of this information directly affects the speed with which your expense check is mailed to you.

Panel member completes information below. DRCJ completes items in italics.

Panel member: _____ Category: _____ E-mail _____

Address: _____ Home Phone: () _____

Contest name: _____ *Location:* _____

Venue Address: _____ *Phone:* () _____

Headquarters hotel/motel: _____

Address: _____ *Phone:* () _____

Alternate place of lodging, if different from above

Address: _____ *Phone:*() _____

First official activity: _____ *Date:* _____ *Start time:* _____

Last official activity: _____ *Date:* _____ *End time:* _____

Conv. Gen Chairman: _____ *Home Phone:* () _____ *E-mail:* _____

Judge Service Chair: _____ *Home Phone:* () _____ *E-mail:* _____

Travel agency to use (direct bill OK): _____ *Phone:* () _____

I. Method of transportation (indicate airfare, mileage, both, or an alternate travel method) Round-trip
coach fare OR Driving at \$.25/mile, _____ miles [whichever is less] \$ _____

Parking, tolls, etc. \$ _____

(please specify) \$ _____

Traveling by car with another panel member? Yes Name: _____

II. Travel information (please indicate arrival time even if driving)

Arrival Date: _____ Time: _____ am/pm Airline/flight #: _____ Airport: _____

Departure Date: _____ Time: _____ am/pm Airline/flight #: _____ Airport: _____

III. Housing information (check off one of the items below) *reimbursement: 1/2 twin rate OR full single rate*

____ Single room ____ Twin bedroom with another panel member: smoker non-smoker

____ My wife _____ will accompany me. Please provide twin / double bedroom. I understand her expenses are my responsibility (except as indicated on this form). Her name is:

____ I have arranged my own accommodations at: _____

TOTAL ALLOWABLE EXPENSES FOR OFFICIAL PANEL MEMBERS CJ-22

(continued)

Phone number for above: (____) _____ Advance expense check? yes no

Panel member signature: _____ Date: _____

DRCJ completes below.

Balance from page 1 \$ _____

IV. Other expenses

Events/meals paid by _____ Time: _____ Place: _____
the convention

Time: _____ Place: _____

Time: _____ Place: _____

Wife/guest expenses paid by the convention: _____

Host chapter will not provide transportation from and to the airport; taxi limo \$

Meals: \$ _____ per diem, _____ days, or:

_____ Breakfasts at \$ _____ each

_____ Lunches at \$ _____ each

_____ Dinners at \$ _____ each

_____ Extra meals while traveling at \$ _____ each

Lodging: _____ nights at \$ _____ 1/2 twin full single prepaid \$

Baggage handling and tips _____ \$

Other expenses: _____

\$

V. Total allowable expenses \$

Adjustments, if any, by contest administrator at contest site _____

\$

Check amount \$

Check # _____ mailed given Date _____

Approved by DRCJ Date _____ Approved by Convention Chairman Date _____

FORM ROUTING

Date received mailed

- _____ DRCJ: Complete all applicable information and send one copy to panel member 8 weeks before the contest
- _____ Panel member: Complete all pertinent items, sign and return to the DRCJ within 5 days of receipt.
- _____ DRCJ: Sign and send 3 copies of the completed form to the Convention General Chairman.
- _____ CGC: Approves expenses, signs and, only if requested by the panel member, sends an advance check to the panel member with a copy of the CJ-22 at least two weeks prior to the contest. The CGC retains one copy, and returns the third copy to the DRCJ

-End of CJ Forms-

AE-08-SD



2010

FWD CHORUS PLATEAU SYSTEM

14.2.1. Plateau Champions. The following score-based plateau titles will be awarded to choruses competing in the divisional contests. The average score of the two most recent appearances in any of the three past Fall District Chorus Contests will determine the plateau placement as follows:

- **Plateau AAA:** Average triple panel score of 1278 (71%) or higher, or any chorus returning to competition after winning the International chorus Championship. Choruses with an average score less than 1278 may voluntarily place themselves into this plateau.
- **Plateau AA:** Average triple panel score from 1098 (61% through 1277 (70.94%) Choruses scoring less than 1098 may voluntarily place themselves into this plateau.
- **Plateau A:** Choruses that have not competed in any of the three most recent Fall District Chorus Contests or have an average triple panel score of less than 1098 (61%) with the exception of any chorus returning to competition after winning the International Chorus Championship.

A chapter may petition the district C&J Committee for plateau reassignment due to significant changes in the chapter. Permission to move to a lower plateau is at the sole discretion of the District C&J committee.

Administration of the plateau assignments will be handled by a coordinate or appointed by the District Representative C&J.

Also--Chapters can find their current plateau standing by going to:

FWD Web Site (www.spebsqsfwd.org)

AE-09-SD



**FAR WESTERN DISTRICT
BARBERSHOP HARMONY SOCIETY**

2010

REGISTRATION AREA CONFIGURATION

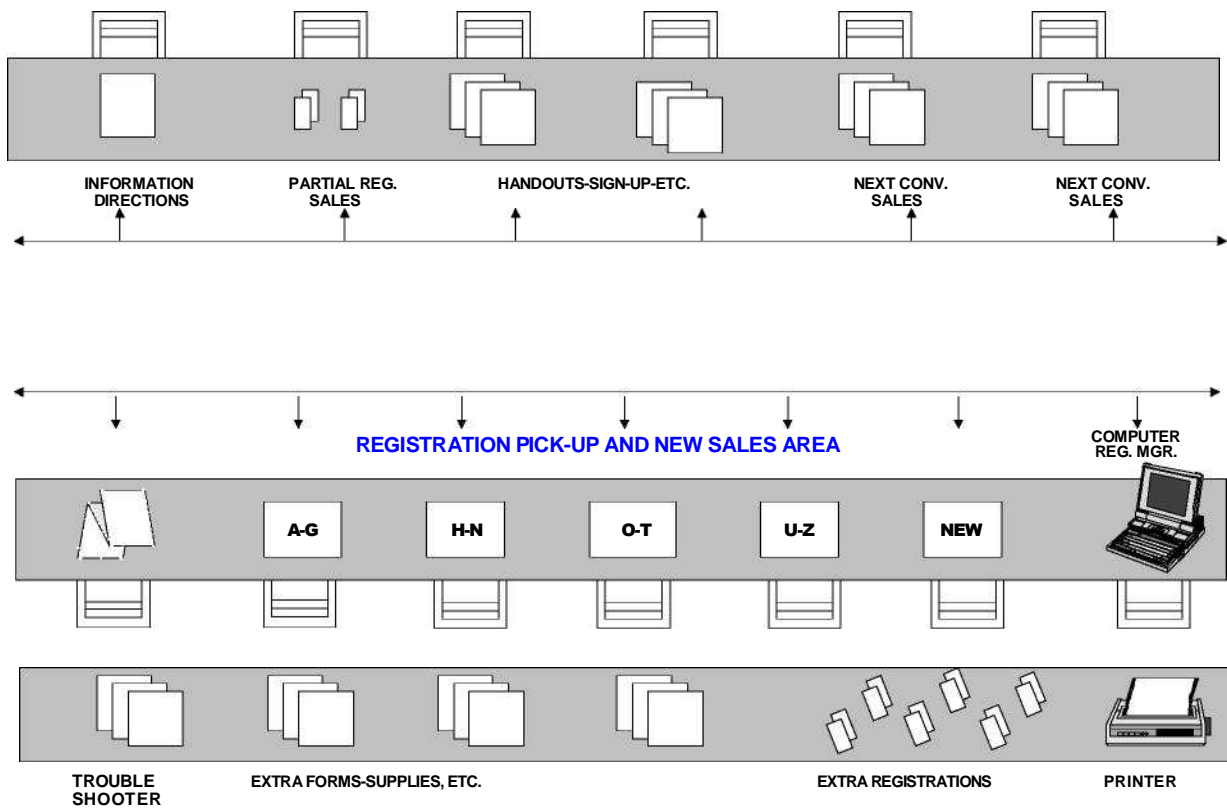

**REGISTRATION
AREA
CONFIGURATION**

AE-10-SD

**SUGGESTED VIP SEATING
 BARBERSHOP HARMONY SOCIETY
 FWD CONVENTION/CONTESTS - **VIP SEATING CHART****

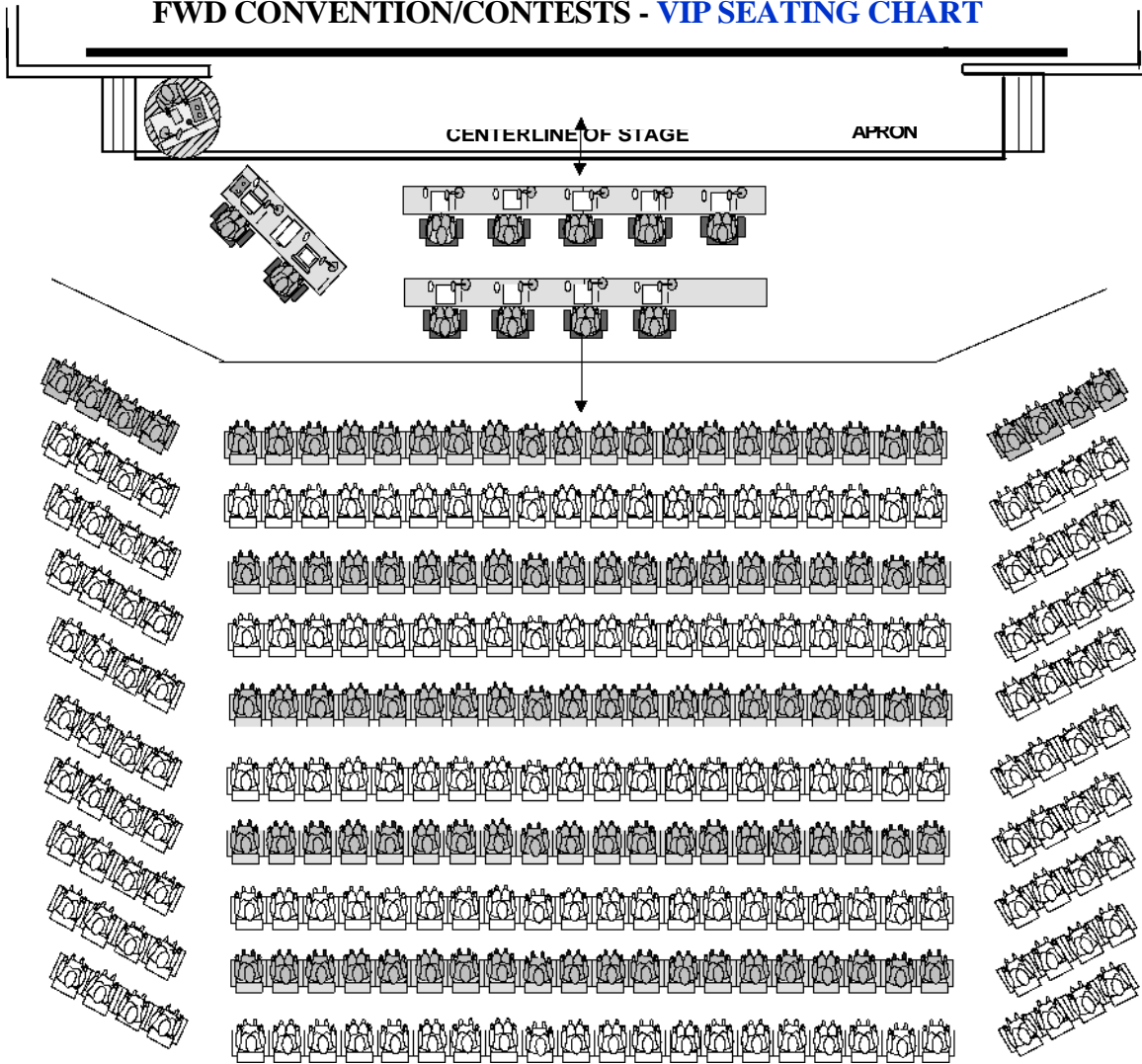

EVERY OTHER ROW - CHANGE AS NEEDED BY CEC

LEST OF CENTER
 District President
 Convention Dedicatee
 Society Representative
 District EX VP
 District CEC
 General Convention Mgr.
 Judges Services Mgr.

**ROW 1 & 3 RIGHT OF CENTER
 (CENTER)**
 Westunes Photographer
 Society Board Member
 Imm Past President
 Division VP's
 Current District Qt. Champs
 Judges Panel & Wives
 Int. Qt. Champs



AE-11-SD



**FAR WESTERN DISTRICT
 BARBERSHOP HARMONY SOCIETY**

2010

**SPRING/DIVISIONAL CONVENTION/CONTESTS
 VIP HOUSING/REGISTRATIONS**

VIP HOUSING and SEATING LIST	# HOTEL ROOMS	# AUD. SEATS	REMARKS
FWD Board of Directors	10	20	
Judging Panel and Wives	*8/12	8/12	Approximate Numbers
Past District Presidents	15	30	
Events Team Managers	8	16	Approximate numbers
AFWDC Members	30	50	Approximate numbers
Members of the H.O.D.	50	75	
District Committee Chairmen	10	20	
Chapter Counselors	20	35	
Hall Of Fame Members	14	24	
FWD Judges (not on panel)	10	20	Approximate numbers
Convention Dedicatee	1	2	
Society Board Member or Rep	1	4	
Westunes Photographer	1	2	
CEC Invited Guests	5	10	Approximate numbers
Misc.			
Total FWD District VIP Rooms & Aud Seats	182	320	Approximate numbers

.District can have double panel (8) and sometimes a triple panel (12) they rarely bring wives..

- NOTE:
1. Many VIP's hold more than one job and are also members of AFWDC, Events, Officers, etc.
 2. Some years the district gives VIP status to special groups, etc.
 3. Only the FWD Chairman of the Events Committee and the President control VIP listing.
 3. Actual list will be available to the Convention Bureau for Headquarters Hotel assigning of rooms and the Events Registration Manager for VIP Seating.
 4. VIP's must make Hotel Reservations and order Convention Registration (seats) at least 45 days prior to convention.



**BARBERSHOP HARMONY SOCIETY
SPEBSQSA, Inc.**

FAR WESTERN DISTRICT

PART B - SECTION 4
SPRING/DIVISIONAL
CONVENTIONS/CONTESTS
ADMINISTRATIVE
SAMPLES

AS-01-SD SAMPLE



**FAR WESTERN DISTRICT
BARBERSHOP HARMONY SOCIETY
2010 SAMPLE LAYOUT**

SPRING/DIVISIONAL WESTUNES AD

8.5"

Far Western District - Barbershop Harmony Society



**SPRING (Int. Prelims) & (Name Division)
CONVENTION/CONTESTS
(Year) CONVENTION/CONTESTS
(Date)**

(List of events and times)

(Location) AUDITORIUM

(Address)

(Chapter Logo)

Hosted by (Name) Chapter

11"

**HEADQUARTERS HOTEL – (name of hotel)
(Address & Phone)**

✂

**USE OFFICIAL DIVISIONAL REGISTRATION FORM
AF-300-SD
IN THIS AREA**

**TOTAL ENCLOSED: \$ _____ Please make check payable to: (Name) (Fees are non-refundable)
Return form with payment to: (Name and address of Registration Chairman)
Phone: (Phone Number) – (Email)**

(Optional) Your Email Address: _____ Confirmation only my Email

AS-02-SD **SAMPLE**



BARBERSHOP ART

JPG formatted, just grab corner and make larger or smaller.

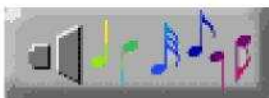



**FAR WESTERN DISTRICT
BARBERSHOP HARMONY SOCIETY**

2010

AWARD PLAQUES

<p>5"</p> <p>8"</p> <p>FAR WESTERN DISTRICT BARBERSHOP HARMONY SOCIETY</p> <p>(FWD LOGO)</p> <p>(Division Name)</p> <p>(Plateau A, AA, or AAA)</p> <p>CHORUS CHAMPIONS</p> <p>CITY, STATE (DATE 00, 0000)</p>	<p>4"</p> <p>6"</p> <p>FAR WESTERN DISTRICT BARBERSHOP HARMONY SOCIETY</p> <p>(FWD LOGO)</p> <p>(Division Name)</p> <p>QUARTET CHAMPIONS</p> <p>CITY, STATE (Date 00, 0000)</p>
---	---

AS-04-SD **SAMPLE**



**FAR WESTERN DISTRICT
BARBERSHOP HARMONY SOCIETY**

2010

COMBINATION PERSON/SEAT BADGES LAYOUT

2010 Fall Convention/Contests
ALL EVENTS
KEVIN PRICE
LEAD – RIVERSIDE CHAPTER
Chorus Director
ROW F - SEAT 16
FWD BARBERSHOP HARMONY SOCIETY

2010 Spring Convention/Contests
ALL EVENTS VIP
ED WATSON
EX-DIRECTOR BHS
Nashville, Tennessee
ROW A - SEAT 18
FWD BARBERSHOP HARMONY SOCIETY

2010 SoCal East Convention/Contests
QUARTET FINALS
SHOW OF CHAMPIONS ONLY
FRANK GILLE
GUEST
OPEN SEATING ONLY
FWD BARBERSHOP HARMONY SOCIETY

2010 Spring/Divisional Convention/Contests
JUDGE
NICK PAPAGEORGE
LA HABRA, CALIFORNIA
JUDGING SOUND
ROW A - SEAT 34
FWD BARBERSHOP HARMONY SOCIETY



FAR WESTERN DISTRICT
 BARBERSHOP HARMONY SOCIETY

2010

SAMPLE DEPOSIT SLIP ACCOUNTING

DATE: 04/07/2009

CHECK #	BANK #	AMOUNT	PERSON	DATE RECD.	# REGS.
5732	16-49	\$ 30.00	Clarence Chinn	03/28/06	1
6555	90-8199	\$ 60.00	Elizabeth & Robert Cossentine	03/30/06	2
7057	16-66	\$ 60.00	Dave & Tine Gunther	03/30/06	2
411	90-7807	\$ 30.00	Buddy Yarnell	04/02/06	1
5512	16-24	\$ 60.00	David & Maureen Johnson	04/02/06	2
2072	90-7162	\$ 210.00	Dennis Woodson +	04/05/06	7
1197	16-66	\$ 30.00	Ken Tillmanns	04/05/06	1
5506	90-8477	\$ 150.00	Jim Ilten +	04/05/06	5
5207	90-4195	\$ 60.00	Jerry Fairchild +	04/05/06	2
TOTAL DEPOSIT		\$ 690.00			

DATE: 04/10/2009

CHECK #	BANK #	AMOUNT	PERSON	DATE RECD.	# REGS.
5930	16-49	\$ 30.00	Bob Griffiths	04/07/06	1
1956	90-7172	\$ 1,050.00	Irvine Chapter	04/07/06	35
7277	16-66	\$ 33.00	Brian Cannon	04/07/06	1
7324	90-7162	\$ 30.00	Frank Terschan	04/10/06	1
4264	16-66	\$ 30.00	Les Lenzner	04/12/06	1
843	90-8260	\$ 30.00	Gay Ferringtin	04/12/06	1
924	90-7162	\$ 30.00	James Larkin	04/12/06	1
2156	90-8200	\$ 60.00	Virgil Pletcher	04/12/06	2
7714	90-3893	\$ 60.00	Bill & Joann	04/13/06	2
3445	90-7162	\$ 30.00	Frank Urban	04/13/06	1
1034	90-7172	\$ 30.00	Richard Esposito	04/13/06	1
TOTAL DEPOSIT		\$ 1,413.00			

DATE: 05/01/2006

CHECK #	BANK #	AMOUNT	PERSON	DATE RECD.	# REGS.
95	90-7162	\$ 825.00	Riverside Chapter	04/25/06	33
7933	16-24	\$ 40.00	Steve Bates (Late)	04/27/06	1
118	90-7162	\$ 160.00	Gray-Men-So-Forte Qt	04/28/06	4
5996	90-7162	\$ 525.00	Brea Chapter	04/28/06	30
TOTAL DEPOSIT		\$ 1,550.00			

DATE: 05/07/2009

CHECK #	BANK #	AMOUNT	PERSON	DATE RECD.	# REGS.
1690		\$ 40.00	L Ray		1
2228		\$ 40.00	C Stahl		1
TOTAL DEPOSIT		\$ 80.00			

DATE: 5/15/2009

DOOR RECEIPTS (see attached)					
		\$ 2,977.00			

TOTAL RECEIPTS \$10,865.00

AS-06-SD SAMPLE



**FAR WESTERN DISTRICT
BARBERSHOP HARMONY SOCIETY
2010 BID SAMPLE**

**SPRING/DIVISIONAL CONTESTS AND CONVENTION
FORM CA-100-SD**

MUST BE SUBMITTED TO CEC BEFORE MARCH BOARD MEETING THREE YEARS (3) PRIOR TO CONVENTION.

Fill out in **TRIPLICATE** and submit as follows: Original to the appropriate CEC (Chairman of the Events Committee), one copy to your **(DVP)** Division Vice President and one copy for your files.

1. BID FOR: **2010** LOCATION: **BAKERSFIELD, CALIFORNIA**
2. NAME OF CHAPTER BIDDING: **BAKERSFIELD** ACTIVE MEMBERS: **45**
3. PROPOSED CONVENTION DATES: **(dates)**
4. **OTHER CHAPTERS** that will provide positive assistance. **None**
5. Estimated number of **ACTIVE MEMBERS** that will work on contest. **35**
6. **PROPOSED GENERAL MANAGER:** Name **BILL ROSICA**

Address **14006 Westdale Drive**
City **Bakersfield**
State/Zip **CA 93312**
Phone Home **(805) 589-4983**
Phone Work **(805) 393-7110**
F a x **(805) 589-4983**
E-mail **aaaaaaa@aol.com**

BARBERSHOP EXPERIENCE: 15 YEARS

CONVENTION EXPERIENCE: 15 years both quartet and chorus. Have held every office in the chapter. AC for 3 years in the District.

7. What percent of **NET PROCEEDS** will be directed to the DISTRICT? **70 %**
(70% is the minimum for FALL CONVENTIONS)
8. Does your chapter hold an **ANNUAL SHOW**? [] YES [] NO
 - a. On what dates? **February**
 - b. If your chapter is awarded this convention, will you still hold an **ANNUAL SHOW**? [] YES [] NO
 - c. What dates? **February**
 - d. What is the **TOP PRICE** for show tickets? **\$15.00**
 - e. How many **TICKETS** do you usually **SELL** to your show? **1,000**
9. How many **REGISTRATIONS** do you plan to sell for this conventions? **800**
10. Please **ATTACH** any other information that would support the bid.

March 2010

SAMPLE BID FOR FWD (FALL) CONTESTS/CONVENTION FORM 100-SD

HOTEL INFORMATION

11. HEADQUARTERS HOTEL: Name **BAKERSFIELD HOLIDAY INN SELECT**
(300 Rooms All Hotels Min.) Address **P.O. Box 2105**
City/State/Zip **Bakersfield, CA 93303**

General Mgr. _____ **Sales Mgr. Susan Mulholland**
Phone (____) _____ Phone **(805) 323-1900**
FAX (____) _____ FAX

Reservations Mgr. _____ **Catering Mgr. Nilda Marquez**
Phone (____) _____ Phone **(805) 323 1900**

Restaurant Mgr. _____ **Security Mgr.** _
Phone (____) _____ Phone (____) _____

12. Has manager been informed of **LATE NIGHT** singing? [] **YES** [] **NO**

13. How many **SLEEPING ROOMS** in hotel? 259

14. How many sleeping rooms are **BLOCKED** for our use? 200

15. List number of rooms **BLOCKED** in **OTHER HOTELS/MOTELS**? 700

16. **TOTAL** rooms blocked in **ALL** hotels/motels? 900

17. **FUNCTION ROOMS** available to us at **HEADQUARTERS HOTEL**? 15
(Board, HOD, Meetings, Afterglow, Rehearsals, Evaluations, Etc.)

18. What **CREDIT CARDS** does hotel except? **VISA, MC, BA, AE, DIS, DC (ALL)**

19. List the **ROOM RATES** for the following types:
SINGLE \$82.00 DOUBLE \$82.00 TWIN \$82.00 DOUBLE/DOUBLE \$82.00
SUITES \$100.00 EXTRA PERSON IN ROOM N/A

20. How many **COMPLIMENTARY ROOMS** for District use? 1/50

21. What are the **CHARGES** for **P.A.**, screens, etc? N/A

22. How many rooms or suites large enough to be acceptable **CHAPTER HOSPITALITY ROOMS**
are available in locations so as not to **DISTURB** other guests? 6

23. Does hotel have 24 hour **EATING FACILITIES**? [] **YES** [] **NO**

24. If not, is there one in the **VICINITY**? [] **YES** [] **NO**

25. How many eating facilities within **WALKING DISTANCE** of the hotel? 10

26. List the **PARKING FACILITIES** and **RATES**. N/A

SAMPLE BID FOR FWD (FALL) CONTESTS/CONVENTION FORM 100-SD

HOTEL INFORMATION Continued

27. Is there **RV PARKING** available? **YES** **NO**

28. How **CLOSE** is the hotel (**H.Q.**) to **SHOPPING**? 5 Miles to Mall

29. Will **ROOM RESERVATIONS** be handled through: **HOTEL/MOTEL** **YES** **NO**
CONVENTION BUREAU **YES** **NO**

30. **CONVENTION BUREAU** Name **BAKERSFIELD CONVENTION BUREAU**
 Address **1325 P Street**
 City/State/Zip **Bakersfield, CA 93301**
 Contact **Ms. Jackie Belluomini VP**
 Phone **(805) 325-5051**

31. **SERVICES PROVIDED** by bureau: Typist for registrations **YES** **NO**
 Name tags furnished **YES** **NO**
 Other services available **YES** **NO**

32. Are there **SIGHTSEEING** and/or **RECREATIONAL FACILITIES** in the area? **YES** **NO**
Local Museum, river rafting on the Kern River, Gold, Tennis Etc.

AUDITORIUM INFORMATION

33. **AUDITORIUM:** Name **BAKERSFIELD CONVENTION CENTER**
 (1200 Seats Minimum) Address **1001 Truxtun Avenue**
 City/State/Zip **Bakersfield, CA 93301**

Contact: **Security**
 Phone _____
 Phone _____
 FAX _____

Aud. Mgr. Mr. Greg Cronk **Stage Mgr.**
 Phone _____ Phone _____

Audio. Mgr. _____ **Lighting Mgr.**
 Phone _____ Phone _____

- | | | | |
|-----------------------------|--|---------------------------------|---|
| a. Seating capacity | <u>2,000</u> | j. Distance from H.Q. Hotel | Adjacent |
| b. Seats cushioned | <input checked="" type="checkbox"/> YES <input type="checkbox"/> NO | k. Transportation needed | <input type="checkbox"/> YES <input checked="" type="checkbox"/> NO |
| c. Permanently installed | <input checked="" type="checkbox"/> YES <input type="checkbox"/> NO | l. Aud. parking facilities | <input checked="" type="checkbox"/> YES <input type="checkbox"/> NO |
| d. Seats numbered | <input checked="" type="checkbox"/> YES <input type="checkbox"/> NO | m. Are ushers required | <input type="checkbox"/> YES <input checked="" type="checkbox"/> NO |
| e. Is floor raised | <input checked="" type="checkbox"/> YES <input checked="" type="checkbox"/> NO | n.. May chapter provide ushers | <input checked="" type="checkbox"/> YES <input type="checkbox"/> NO |
| f. Orch. Pit/Judges area | <input checked="" type="checkbox"/> YES <input type="checkbox"/> NO | o. Aud/lobby separated by doors | <input checked="" type="checkbox"/> YES <input type="checkbox"/> NO |
| g. Air Conditioned | <input checked="" type="checkbox"/> YES <input type="checkbox"/> NO | p. Tickets from Aud/only | <input type="checkbox"/> YES <input checked="" type="checkbox"/> NO |
| h. Aud. sound system | <input checked="" type="checkbox"/> YES <input type="checkbox"/> NO | q. Seating chart/plan avail | <input checked="" type="checkbox"/> YES <input type="checkbox"/> NO |
| i. Stage lighting available | <input checked="" type="checkbox"/> YES <input type="checkbox"/> NO | r. Overnight RV parking Aud. | <input checked="" type="checkbox"/> YES <input type="checkbox"/> NO |

SAMPLE BID FOR FWD (FALL) CONTESTS/CONVENTION FORM 100-SD

AUDITORIUM INFORMATION Continued

34. Area for **QUARTET/CHORUS PHOTOS** available **YES** **NO**

35. DRESSING ROOMS:

- a. How many **DRESSING ROOMS** available for **QUARTETS**? **30** Size **20x20'**
- b. How many **DRESSING ROOMS** available for **CHORUSES**? **30** Size **20x20'**

36. STAGE INFORMATION:

- a. How **WIDE** is stage? Ft. **100 ft.**
- b. How **DEEP** is stage? Ft. **70 ft.**
- c. Main curtain **TRAVEL** **FLY**
- d. Main curtain **ELECT** **MANUAL**

37. Separate **ACCESS** to back stage area? **YES** **NO**

38. Chorus **SHELL SECTIONS** available? **YES** **NO**

39. Chorus **RISERS** that meet **DISTRICT REQUIREMENTS**? **YES** **NO**
(Will set to largest chorus competing requirements up to 11 sections
of 4 step standard Wenger or wood type.)

40. Estimated **AUDITORIUM COST**? **\$5,250.00**
(Including house, ushers, stage hands, electricians etc.)

41. REMARKS: Add comments on anything you feel would be considered. No rental fee for auditorium use. Headquarters Hotel directly next door. Plenty of rooms for larger choruses to use for rehearsal. Chapter has hosted many times in the past.

We have read the **FWD CONVENTION REGULATIONS** and are familiar with the responsibilities and duties connected with hosting this convention for which this chapter is bidding. We understand that the **GENERAL CONVENTION CHAIRMAN** must attend the **CONVENTION PLANNING CLASS AT COTS** prior to said convention.

Chapter President :	Date	January 12, 2007
General Convention Chairman:	Date	January 12, 2007
Chapter Secretary:	Date	January 12, 2007

INSPECTED BY: CEC:	Date	February 2, 2007
DRJC:	Date	February 2, 2007
PRO. DIR:	Date	February 2, 2007

AS-07-SD SAMPLE

SAMPLE - SPRING/DIVISION 2008 PRELIMINARY BUDGET FINANCIAL STATEMENT -
 EXHIBIT DS-H1-C HOST CHAPTER RUN FORM CA-1015x-C Rev. 01/06 lg

LOCATION: Servite High School, Anaheim CA
 EVENT: FWD SPRING/DIVISION Convention/Contests
 MANAGEMENT: Riverside "The New Gang On The Corner"
 DATE(S): March 13-16, 2008

SUMMARY	PRELIM BUDGET	TOTAL REG. SALES
TOTAL INCOME \$	47,275.00	PRELIM. 1150
TOTAL EXPENSES \$	15,975.00	
NET PROFIT/LOSS \$	30,300.00	
70% NET PROFIT TO DISTRICT \$	21,210.00	
30% NET PROFIT TO HOST CHAPTER \$	9,090.00	

CODE INCOME:	PRELIM BUDGET QUANTITY	PRELIM BUDGET EACH	PRELIM BUDGET TOTAL
101 ALL EVENTS EARLY BIRD	700 \$	40.00 \$	28,000.00
102 ALL EVENTS LATE/ON SITE	200 \$	50.00 \$	10,000.00
103 ALL EVENTS EARLY BIRD CHILD/STUDENT	40 \$	20.00 \$	800.00
104 ALL EVENTS CHILD/STUDENT LATE/ON SITE	10 \$	30.00 \$	300.00
105 SINGLE EVENT - FRI. QT. SEMI FINALS	10 \$	30.00 \$	300.00
106 SINGLE EVENT - SAT. CHORUS CONTEST	15 \$	30.00 \$	450.00
107 SINGLE EVENT - SAT. QUARTET FINALS/SHOW	150 \$	30.00 \$	4,500.00
108 COMP. REGISTRATIONS	25 \$	40.00 \$	1,000.00
SUB TOTAL	1150		\$45,350.00
109 PROGRAM AD SALES	10 \$	50.00 \$	500.00
110 RV PARKING @ \$	25 \$	5.00 \$	125.00
111 TRANSPORTATION @ (\$ price)	0 \$	- \$	-
112 HOTEL CREDIT - COMP ROOMS	0 \$	- \$	1,000.00
113 OTHER INCOME MISC. (10% BS Shop Sales)	0 \$	- \$	300.00
114	0 \$	- \$	-
115	0 \$	- \$	-
116	0 \$	- \$	-
SUB TOTAL			\$1,925.00
100 TOTAL INCOME			\$47,275.00

CODE EXPENSES	BUDGET	TOTAL
201 RENTAL - AUDITORIUM	\$ 1,200.00	
202 RENTAL - ROOMS/EXTRA	\$ -	
203 RENTAL - RADIO COMMUNICATIONS	\$ 150.00	
204 RENTAL - AUDIO/VIDEO EQUIPMENT/EXTRA	\$ 3,000.00	
205 RENTAL - LIGHTING/EXTRA	\$ -	
206 RENTAL - MISC.	\$ -	
207 LABOR - STAGE HAND(S)	\$ 2,000.00	
208 LABOR - ELECTRICIAN(S)	\$ -	
209 LABOR - AUDIO/VIDEO TECHNICIAN(S)	\$ -	
210 LABOR - CUSTODIAN(S)	\$ -	
211 LABOR - SECURITY(S)	\$ -	
212 LABOR - USHERS	\$ -	
213 OTHER AUDITORIUM EXPENSES	\$ 100.00	
200 TOTAL AUDITORIUM EXPENSE	\$ 6,450.00	\$6,450.00
301 JUDGES TRAVEL	\$ 3,500.00	
302 JUDGES HOUSING	\$ 2,500.00	
303 JUDGES MEALS	\$ 500.00	
304 JUDGES MISC.	\$ 100.00	
305 JUDGES SERVICES REFRESHMENTS/ETC.	\$ 150.00	
300 TOTAL JUDGES EXPENSES	\$ 6,750.00	\$6,750.00
402 AUDIO/VIDEO TAPES	\$ 100.00	
403 AWARDS & TROPHIES	\$ -	
404 HOTEL MISC. COFFEE/ETC.	\$ 300.00	
405 HOTEL ROOM DEDICATEE	\$ 250.00	
406 HOTEL ROOM MISC.	\$ -	
407 INSURANCE	\$ -	
408 LADIES HOSPITALITY	\$ 100.00	
409 POSTAGE & TELEPHONE	\$ 150.00	
410 PRINTING MISC. FLYERS/ETC.	\$ 125.00	
411 PRINTING PROGRAM	\$ 300.00	
412 PRINTING SIGNS & SCORE SHEETS	\$ 100.00	
413 PUBLICITY DISTRICT/PUBLIC	\$ 100.00	
414 REGISTRATION & MISC. SUPPLIES	\$ 300.00	
415 TRANSPORTATION (EXCLUDING JUDGES)	\$ 1,000.00	
416 REGISTRATION COMPS	\$ 750.00	
417 GCC EXPENSES	\$ 100.00	
418 OTHER MISC. EXPENSES	\$ 100.00	
400 TOTAL SUPPLIES/SERVICE/ETC.	\$ 3,775.00	\$3,775.00

CODE	Not Used
501	
502	
503	
504	
505	
506	
507	
508	

600 TOTAL EXPENSES \$ 16,375.00

CODE TOTALS

100	TOTAL INCOME	\$	27,275.00
600	TOTAL EXPENSES	\$	16,375.00
700	NET PROFIT/LOSS	\$	10,900.00
701	70% NET PROFIT TO DISTRICT	\$	7,630.00
702	30% NET PROFIT TO HOST CHAPTER	\$	3,270.00

Bill Stone

 SIGNED (GENERAL MANAGER)

 (date signed)

 DATE:

Polly Grossman

 SIGNED (EXECUTIVE GENERAL MANAGER)

 (date signed)

 DATE:

AS-08-SD SAMPLE

SAMPLE - SPRING/DIVISION 2008 REVISED FINANCIAL STATEMENT

EXHIBIT DS-H2C - HOST CHAPTER RUN FORM CA-1025x-C Rev. 01/09 fg

LOCATION: Servite High School, Anaheim, CA
 EVENT: FWD SPRING/DIVISION Convention/Contests
 MANAGEMENT: Riverside "The New Gang On The Corner"
 DATE(S): March 13-16, 2008

Far Western District



SUMMARY	PRELIM BUDGET	REVISED BUDGET	VARIANCE	TOTAL REG. SALES
TOTAL INCOME	\$ 47,275.00	\$ 47,275.00	\$ -	PRELIM 1150
TOTAL EXPENSES	\$ 16,875.00	\$ 16,750.00	\$ (125.00)	REVISED 1150
NET PROFIT/LOSS	\$ 30,400.00	\$ 30,525.00	\$ 125.00	VARIANCE 0
70% NET PROFIT TO DISTRICT	\$ 21,280.00	\$ 21,367.50	\$ (77.50)	
30% NET PROFIT TO HOST CHAPTER	\$ 9,120.00	\$ 9,157.50	\$ 37.50	

CODE INCOME:	PRELIM BUDGET QUANTITY	PRELIM BUDGET EACH	PRELIM BUDGET TOTAL	REVISED BUDGET QUANTITY	REVISED BUDGET EACH	REVISED BUDGET TOTAL	OVER/ UNDER BUDGET
101 ALL EVENTS EARLY BIRD	700	\$ 40.00	\$ 28,000.00	700	\$ 40.00	\$ 28,000.00	\$ -
102 ALL EVENTS LATE/ON SITE	200	\$ 50.00	\$ 10,000.00	200	\$ 50.00	\$ 10,000.00	\$ -
103 ALL EVENTS EARLY BIRD CHILD/STUDENT	40	\$ 20.00	\$ 800.00	40	\$ 20.00	\$ 800.00	\$ -
104 ALL EVENTS CHILD/STUDENT LATE/ON SITE	10	\$ 30.00	\$ 300.00	10	\$ 30.00	\$ 300.00	\$ -
105 SINGLE EVENT - FRI. QT. SEMI FINALS	10	\$ 30.00	\$ 300.00	10	\$ 30.00	\$ 300.00	\$ -
106 SINGLE EVENT - SAT. CHORUS CONTEST	15	\$ 30.00	\$ 450.00	15	\$ 30.00	\$ 450.00	\$ -
107 SINGLE EVENT - SAT. QUARTET FINALS/SHOW	150	\$ 30.00	\$ 4,500.00	150	\$ 30.00	\$ 4,500.00	\$ -
108 COMP. REGISTRATIONS	25	\$ 40.00	\$ 1,000.00	25	\$ 40.00	\$ 1,000.00	\$ -
SUB TOTAL	1150		\$45,350.00	1150		\$ 45,350.00	\$ -
109 PROGRAM AD SALES	10	\$ 50.00	\$ 500.00	10	\$ 50.00	\$ 500.00	\$ -
110 RV PARKING @ \$	25	\$ 5.00	\$ 125.00	25	\$ 5.00	\$ 125.00	\$ -
111 TRANSPORTATION @ (\$ price)	0	\$ -	\$ -	0	\$ -	\$ -	\$ -
112 HOTEL CREDIT - COMP ROOMS	0	\$ -	\$ 1,000.00	0	\$ -	\$ 1,000.00	\$ -
113 OTHER INCOME MISC. (10% BS Shop Sales)	0	\$ -	\$ 300.00	0	\$ -	\$ 300.00	\$ -
114	0	\$ -	\$ -	0	\$ -	\$ -	\$ -
115	0	\$ -	\$ -	0	\$ -	\$ -	\$ -
116	0	\$ -	\$ -	0	\$ -	\$ -	\$ -
SUB TOTAL			\$1,925.00			\$1,925.00	\$ -
100 TOTAL INCOME			\$47,275.00			\$47,275.00	\$ -

CODE EXPENSES	PRELIM TOTAL	REVISED TOTAL	OVER/ UNDER BUDGET
201 RENTAL - AUDITORIUM	\$ 1,200.00	\$ 1,200.00	\$ -
202 RENTAL - ROOMS/EXTRA	\$ -	\$ -	\$ -
203 RENTAL - RADIO COMMUNICATIONS	\$ 150.00	\$ 150.00	\$ -
204 RENTAL - AUDIO/VIDEO EQUIPMENT/EXTRA	\$ 3,000.00	\$ 3,000.00	\$ -
205 RENTAL - LIGHTING/EXTRA	\$ -	\$ -	\$ -
206 RENTAL - MISC.	\$ -	\$ -	\$ -
207 LABOR - STAGE HAND(S)	\$ 2,000.00	\$ 2,000.00	\$ -
208 LABOR - ELECTRICIAN(S)	\$ -	\$ -	\$ -
209 LABOR - AUDIO/VIDEO TECHNICIAN(S)	\$ -	\$ -	\$ -
210 LABOR - CUSTODIAN(S)	\$ -	\$ -	\$ -
211 LABOR - SECURITY(S)	\$ -	\$ -	\$ -
212 LABOR - USHERS	\$ -	\$ -	\$ -
213 OTHER AUDITORIUM EXPENSES	\$ 100.00	\$ -	\$ (100.00)
200 TOTAL AUDITORIUM EXPENSE	\$ 6,450.00	\$ 6,350.00	\$ (100.00)
301 JUDGES TRAVEL	\$ 3,500.00	\$ 3,800.00	\$ 300.00
302 JUDGES HOUSING	\$ 2,500.00	\$ 2,500.00	\$ -
303 JUDGES MEALS	\$ 500.00	\$ 500.00	\$ -
304 JUDGES MISC.	\$ 100.00	\$ 100.00	\$ -
305 JUDGES SERVICES REFRESHMENTS/ETC.	\$ 150.00	\$ 150.00	\$ -
300 TOTAL JUDGES EXPENSES	\$ 6,750.00	\$ 7,050.00	\$ 300.00
402 AUDIO/VIDEO TAPES	\$ 100.00	\$ 75.00	\$ (25.00)
403 AWARDS & TROPHIES	\$ -	\$ -	\$ -
404 HOTEL MISC. COFFEE/ETC.	\$ 300.00	\$ 300.00	\$ -
405 HOTEL ROOM DEDICATEE	\$ 250.00	\$ 300.00	\$ 50.00
406 HOTEL ROOM MISC.	\$ -	\$ -	\$ -
407 INSURANCE	\$ -	\$ -	\$ -
408 LADIES HOSPITALITY	\$ 100.00	\$ 100.00	\$ -
409 POSTAGE & TELEPHONE	\$ 150.00	\$ 100.00	\$ (50.00)
410 PRINTING MISC. FLYERS/ETC.	\$ 125.00	\$ 100.00	\$ (25.00)
411 PRINTING PROGRAM	\$ 300.00	\$ 250.00	\$ (50.00)
412 PRINTING SIGNS & SCORE SHEETS	\$ 100.00	\$ 75.00	\$ (25.00)
413 PUBLICITY DISTRICT/PUBLIC	\$ -	\$ -	\$ -
414 REGISTRATION & MISC. SUPPLIES	\$ 300.00	\$ 300.00	\$ -
415 TRANSPORTATION (EXCLUDING JUDGES)	\$ 1,000.00	\$ 800.00	\$ (200.00)
416 REGISTRATION COMPS	\$ 750.00	\$ 750.00	\$ -
417 GCC EXPENSES	\$ 100.00	\$ 100.00	\$ -
418 OTHER MISC. EXPENSES	\$ 100.00	\$ 100.00	\$ -
400 TOTAL SUPPLIES/SERVICE/ETC.	\$ 3,675.00	\$ 3,350.00	\$ (325.00)

CODE EXPENSES (Not Used)	PRELIM	TOTAL	REVISED	TOTAL
501				\$ -
502				\$ -
503				\$ -
504				\$ -
505				\$ -
506				\$ -
507				\$ -
600 TOTAL EVENTS MGMT. EXPENSES	\$ -	\$ -	\$ -	\$ -
600 TOTAL EXPENSES		\$ 16,875.00		\$ 16,790.00 \$ (125.00)
CODE TOTALS				
100 TOTAL INCOME		\$ 47,275.00		\$ 47,275.00 \$ -
600 TOTAL EXPENSES		\$ 16,875.00		\$ 16,790.00 \$ (125.00)
700 NET PROFIT/LOSS		\$ 30,400.00		\$ 30,525.00 \$ 125.00
701 70% NET PROFIT TO DISTRICT		\$ 21,280.00		\$ 18,315.00 \$ (2,965.00)
702 30% NET PROFIT TO HOST CHAPTER		\$ 9,120.00		\$ 9,167.50 \$ 37.50

Bill Schuss

 SIGNED (GENERAL MANAGER)

 (date signed)
 DATE:

Felix Grossmann

 SIGNED (EXECUTIVE GENERAL MANAGER)

 (date signed)
 DATE:

SAMPLE - SPRING/DIVISION 2008 FINAL FINANCIAL STATEMENT

EXHIBIT DS-H3C - FORM CA-103Sx-C Rev. 01/09 fg

LOCATION: Servite High School Anaheim, CA
 EVENT: FWD SPRING/DIVISIONAL Convention/Contests
 MANAGEMENT: Riverside "The New Gang On The Corner"
 DATE(S): March 13-16, 2008

Far Western District



SUMMARY	REVISED BUDGET	ACTUAL BUDGET	VARIANCE	TOTAL REG. SOLD
TOTAL INCOME	\$ 47,275.00	\$ 51,402.00	\$ 4,127.00	REVISED 1265
TOTAL EXPENSES	\$ 16,750.00	\$ 15,879.22	\$ (870.78)	ACTUAL 1150
NET PROFIT/LOSS	\$ 30,525.00	\$ 35,522.78	\$ 4,997.78	VARIANCE 115
70% NET PROFIT TO DISTRICT	\$ 21,367.50	\$ 21,313.67	\$ (53.83)	
30% NET PROFIT TO HOST CHAPTER	\$ 9,157.50	\$ 10,656.83	\$ 1,499.33	

CODE	INCOME:	REVISED BUDGET QUANTITY	REVISED BUDGET EACH	REVISED BUDGET TOTAL	ACTUAL BUDGET QUANTITY	ACTUAL BUDGET EACH	ACTUAL BUDGET TOTAL	OVER/ UNDER BUDGET
101	ALL EVENTS EARLY BIRD	700	\$ 40.00	\$ 28,000.00	735	\$ 40.00	\$ 29,400.00	\$ 1,400.00
102	ALL EVENTS LATE/ON SITE	200	\$ 50.00	\$ 10,000.00	212	\$ 50.00	\$ 10,600.00	\$ 600.00
103	ALL EVENTS EARLY BIRD CHILD/STUDENT	40	\$ 20.00	\$ 800.00	42	\$ 20.00	\$ 840.00	\$ 40.00
104	ALL EVENTS CHILD/STUDENT LATE/ON SITE	10	\$ 30.00	\$ 300.00	8	\$ 30.00	\$ 240.00	\$ (60.00)
105	SINGLE EVENT - FRI. QT. SEMI FINALS	10	\$ 30.00	\$ 300.00	5	\$ 30.00	\$ 150.00	\$ (150.00)
106	SINGLE EVENT - SAT. CHORUS CONTEST	15	\$ 30.00	\$ 450.00	44	\$ 30.00	\$ 1,320.00	\$ 870.00
107	SINGLE EVENT - SAT. QUARTET FINALS/SHOW	150	\$ 30.00	\$ 4,500.00	198	\$ 30.00	\$ 5,940.00	\$ 1,440.00
108	COMP. REGISTRATIONS	25	\$ 40.00	\$ 1,000.00	21	\$ 40.00	\$ 840.00	\$ (160.00)
	SUB TOTAL	1150		\$45,350.00	1265		\$ 49,330.00	\$ 3,980.00
109	PROGRAM AD SALES	10	\$ 50.00	\$ 500.00	12	\$ 50.00	\$ 600.00	\$ 100.00
110	RV PARKING @ \$	25	\$ 5.00	\$ 125.00	18	\$ 5.00	\$ 90.00	\$ (35.00)
111	TRANSPORTATION @ \$	0	\$ -	\$ -	0	\$ -	\$ -	\$ -
112	HOTEL CREDIT - COMP ROOMS	0	\$ -	\$ 1,000.00	0	\$ -	\$ 1,000.00	\$ -
113	OTHER INCOME MISC. (10% BS Shop Sales)	0	\$ -	\$ 300.00	0	\$ -	\$ 382.00	\$ 82.00
114		0	\$ -	\$ -	0	\$ -	\$ -	\$ -
115		0	\$ -	\$ -	0	\$ -	\$ -	\$ -
116		0	\$ -	\$ -	0	\$ -	\$ -	\$ -
	SUB TOTAL			\$1,925.00			\$2,072.00	\$ 147.00
100	TOTAL INCOME			\$47,275.00			\$51,402.00	\$ 4,127.00

CODE	EXPENSES	REVISED	TOTAL	ACTUAL	TOTAL
201	RENTAL - AUDITORIUM	\$ 1,200.00		\$ 1,195.00	\$ (5.00)
202	RENTAL - ROOMS/EXTRA	\$ -		\$ -	\$ -
203	RENTAL - RADIO COMMUNICATIONS	\$ 150.00		\$ 148.50	\$ (1.50)
204	RENTAL - AUDIO/VIDEO EQUIPMENT/EXTRA	\$ 3,000.00		\$ 3,195.12	\$ 195.12
205	RENTAL - LIGHTING/EXTRA	\$ -		\$ -	\$ -
206	RENTAL - MISC	\$ -		\$ -	\$ -
207	LABOR - STAGE HAND(S)	\$ 2,000.00		\$ 2,013.00	\$ 13.00
208	LABOR - ELECTRICIAN(S)	\$ -		\$ -	\$ -
209	LABOR - AUDIO/VIDEO TECHNICIAN(S)	\$ -		\$ -	\$ -
210	LABOR - CUSTODIAN(S)	\$ -		\$ -	\$ -
211	LABOR - SECURITY(S)	\$ -		\$ -	\$ -
212	LABOR - USHERS	\$ -		\$ -	\$ -
213	OTHER AUDITORIUM EXPENSES	\$ -		\$ -	\$ -
200	TOTAL AUDITORIUM EXPENSE	\$ 6,350.00	\$6,350.00	\$ 6,551.62	\$ 201.62
301	JUDGES TRAVEL	\$ 3,800.00		\$ 3,842.60	\$ 42.60
302	JUDGES HOUSING	\$ 2,500.00		\$ 2,539.04	\$ 39.04
303	JUDGES MEALS	\$ 500.00		\$ 212.00	\$ (288.00)
304	JUDGES MISC.	\$ 100.00		\$ -	\$ (100.00)
305	JUDGES SERVICES REFRESHMENTS/ETC.	\$ 150.00		\$ 178.72	\$ 28.72
300	TOTAL JUDGES EXPENSES	\$ 7,050.00	\$7,050.00	\$ 6,772.36	\$ 277.64
402	AUDIO/VIDEO TAPES	\$ 75.00		\$ 74.68	\$ (0.32)
403	AWARDS & TROPHIES	\$ -		\$ -	\$ -
404	HOTEL MISC. COFFEE/ETC.	\$ 300.00		\$ 389.43	\$ 89.43
405	HOTEL ROOM DEDICATEE	\$ 300.00		\$ 309.12	\$ 9.12
406	HOTEL ROOM MISC.	\$ -		\$ -	\$ -
407	INSURANCE	\$ -		\$ -	\$ -
408	LADIES HOSPITALITY	\$ 100.00		\$ 52.00	\$ (48.00)
409	POSTAGE & TELEPHONE	\$ 100.00		\$ 36.90	\$ (63.10)
410	PRINTING MISC. FLYERS/ETC.	\$ 100.00		\$ 78.45	\$ (21.55)
411	PRINTING PROGRAM	\$ 250.00		\$ 185.76	\$ (64.24)
412	PRINTING SIGNS & SCORE SHEETS	\$ 75.00		\$ 38.00	\$ (37.00)
413	PUBLICITY DISTRICT/PUBLIC	\$ -		\$ -	\$ -
414	REGISTRATION & MISC. SUPPLIES	\$ 300.00		\$ 254.90	\$ (45.10)
415	TRANSPORTATION (EXCLUDING JUDGES)	\$ 800.00		\$ 450.00	\$ (350.00)
416	REGISTRATION COMPS	\$ 750.00		\$ 630.00	\$ (120.00)
417	GCC EXPENSES	\$ 100.00		\$ 43.10	\$ (56.90)
418	OTHER MISC. EXPENSES	\$ 100.00		\$ 12.90	\$ (87.10)

400 TOTAL SUPPLIES/SERVICE/ETC. \$ 3,350.00 \$3,350.00 \$ 2,555.24 \$2,555.24 \$ (794.76)

CODE EXPENSES (Not Used)	REVISED	TOTAL	ACTUAL	TOTAL
501				\$ -
502				\$ -
503				\$ -
504				\$ -
505				\$ -
506				\$ -
507				\$ -
500 TOTAL EVENTS MGMT. EXPENSES	\$ -	\$ -	\$ -	\$ -
600 TOTAL EXPENSES		\$ 16,750.00		\$ 15,879.22 \$ (870.78)
CODE TOTALS				
100 TOTAL INCOME		\$ 47,275.00		\$ 51,402.00 \$ 4,127.00
600 TOTAL EXPENSES		\$ 16,750.00		\$ 15,879.22 \$ (870.78)
700 NET PROFIT/LOSS		\$ 30,525.00		\$ 35,522.78 \$ 4,997.78
701 70% NET PROFIT TO DISTRICT		\$ 21,367.50		\$ 21,313.87 \$ (53.63)
702 30% NET PROFIT TO HOST CHAPTER		\$ 9,157.50		\$ 10,658.83 \$ 1,499.33

Bill Schuss

 SIGNED (GENERAL MANAGER)

(Date Signed)

 DATE:

Judy Grosswald

 SIGNED (EXECUTIVE GENERAL MANAGER)

(Date Signed)

 DATE:

AS-10-SD SAMPLE



**FAR WESTERN DISTRICT
BARBERSHOP HARMONY SOCIETY**

2010

SPRING/DIVISIONAL FLYER SAMPLE LAYOUT

8.5"

Far Western District - Barbershop Harmony Society

(FWD LOGO)

SPRING (Int. Prelims) (Name Division)
CONVENTION/CONTESTS
(Year) CONVENTION/CONTESTS
(Date)
(List of events and times)
(Location) AUDITORIUM
(Address)

(Chapter Logo)
Hosted by (Name) Chapter

HEADQUARTERS HOTEL – (name of hotel)
(Address & Phone)

To register, complete the form below (or copy of it), attach your check made out to (name), and send to
(Name and address of Registration Chairman)
Questions? Call (Phone Number) – (Email)

✂

**USE OFFICIAL DIVISIONAL REGISTRATION FORM
AF-300-SD**

IN THIS AREA

TOTAL ENCLOSED: \$ _____ Please make check payable to: (Name) (Fees are non-refundable)
Return form with payment to: (Name and address of Registration Chairman)
Phone: (Phone Number) – (Email)

(Optional) Your Email Address: _____ Confirmation only my Email

AS-11-SD



(Convention Name)

**FAR WESTERN DISTRICT
BARBERSHOP HARMONY SOCIETY**

SAMPLE HOST - CHORUS LETTER

Gentlemen:

Enclosed with this letter is a diagram of the Convention Center (school) site, showing locations of key activities and a new schedule of each performing group's progress through the event. Chorus members' first place to arrive Saturday morning is the "Arena." Please enter from either the Arena Lobby or the East Concourse entrances. Dressing areas for each group will be designated, and an escort will meet you there to guide you through the auditorium facilities. There is only room in the Arena for a limited number of dressing areas. As a result Choruses will be using the same dressing area. Please do not arrive in the arena prior to your assigned time, as an earlier group may still need the space. Also please remove your belongings as soon as possible to make room for the next chorus.

Could you please let me know if you have any member with special needs (i.e. wheelchairs) or if your chorus has unusual props or other considerations for your movement backstage?

We're looking forward to showing you a great time in (location of convention). If you have any comments, questions or suggestions, please feel free to call me at xxx xxx-xxxx or you may e-mail me at xxx xxx xxxx.

Sincerely,
Host Committee



(Convention Name)
**FAR WESTERN DISTRICT
BARBERSHOP HARMONY SOCIETY**

SAMPLE HOST - QUARTET LETTER

Gentlemen:

Enclosed with this letter is a diagram of the Convention Center (school) site, showing locations of key activities and a new schedule of each performing group's progress through the event. Quartets, as you know, will be provided dressing/warm-up rooms for your convenience; you do not need to use them if you choose not to. When you arrive, please check in at the table in the area labeled "Arena Lobby" and an escort will meet you there and guide you through the auditorium facilities. Two quartets will be assigned to each dressing room; please do not arrive earlier than your assigned time, as an earlier group will still need the room.

All quartets are invited to sing at the Saturday night *Afterglow*; they will perform in the order in which they sign up. Competing quartets will have the *opportunity* to sign up for choice early slots when they check in at the Arena Lobby.

We're looking forward to showing you a great time in (convention location). If you have any comments, questions or suggestions, please feel free to call me at xxx-xxx-xxxx or you may e-mail me at xxx.xxx xxxx

-End of Host Letters-

AS-12-SD **SAMPLE**



FAR WESTERN DISTRICT BARBERSHOP HARMONY SOCIETY **2010**

SAMPLE CHAIRMAN OF JUDGES CHECKLIST AND CONVENTION CHAIRMAN'S ANSWERS

Contest General Chairman, **(name)**

Event: **FWD (Name) SPRING/DIVISIONAL CONTEST** Location: **(City)** Date: **(date)** Facilities.

- Judges Ready Room ("Green room") backstage with adjacent rest room facilities.
- Information on main curtain: **(manual/motor, time to open/close, etc.) (have to time it)**
- Quartet monitor **speakers** (or shell) and a shell **(no)** for the chorus contest.
- Sound system designed and set up for a cappella singing. **(yes)**
- Lighting system designed to focus light on front portion of the stage ahead of the curtain for quartets. **(yes)**
- Lighting system designed to focus light evenly across all riser sections for choruses **(yes)**
- **4** each 6' to 8' sturdy tables and **10 comfortable** chairs for judges and CAs.
- Adequate 110 volt AC power outlets in the judging area (not connected to house dimming circuits) to handle eight table lamps, two computers, two printers and 2 calculators. Heavy duty (#16 three wire) extension cords and distribution boxes. **(yes)**
- Push brooms available backstage for cleaning between chorus performances, if needed. **(yes)**
- 50 sheets of blank, laser quality 8.5" x 11" paper. **(yes)**
- 25 sheets of blank, laser quality 8.5" x 14" paper (for a large chorus contest).
- Bottled water (pints/quarts) and Styrofoam cups at each judging station **(yes)**
- Roll of paper towels to clean up spills in the judges area. **(yes)**
- Emergency telephone location identified **(will check for location)**

Personnel Tasks.

- Someone to help with the set up of the judges area prior to the contest. **(stage crew assigned)**
- Someone to help with the breakdown of the judges area after the contest. **(stage crew assigned)**
- Someone on permanent assignment to the judges' area during each contest session. **(yes)**
- Someone backstage to count men on stage for each chorus competitor. **(yes)**
- One runner responsible for the printing and distribution of the contest scoring summaries. **(Joe Shaw)**
- Someone responsible for monitoring judges' water needs between sessions. **(Emmett Bossing)**
- One mike testing quartet before the contest begins to set sound levels. **(one will be available)**

Logistics. **(will send when available)**

- The plan for contest schedules cleared with the DVP C&J and CA.
- Order of appearance provided in advance to CA.
- Plan for transportation to move judges between the contest site and headquarters hotel.
- Plan for the efficient movement of contestants to/from dressing areas, warm-up, and stage.
- Plan for announcing contest results to audience.
- Plan for presenting trophies to winners--identifying presenters.
- Plan for **audio/video**/photography of contestants as desired.
- Identify facility for printing score sheets (open late and on Sundays).
- Plan for distribution of scoring summaries at hotels and contest site.
- Order judges' ribbons and prepare packet with tickets, badges and information for each judge. (We no longer use ribbons but will deliver badges, programs, etc. to judges room during meeting.)
- Provide beverages and light snacks in judge's ready room. **(yes)**
- Provide mints at judges stations (optional). **(yes)**

AS-13-SD SAMPLE



2010

SAMPLE PANEL MEMBER JUDGES ALLOWABLE EXPENSES

Panel Member: (Name) Category: xxxxxx Phone: xxx xxx xxxx Cell: xxx xxx xxxx
 Address xxxxxxxxxxxxxxxx Email: xxxxxxxxxxxx

Contest Name: FWD xxxxxxxxxxxxxxxx Location: xxxxxxxxxxxxxxxx
 Address xxxxxxxxxxxxxxxx

Headquarters: Name xxxxxxxxxxxx
 Address xxxxxxxxxxxxxxxx Telephone: xxx xxx xxxx

First Official activity: Judges briefing/lunch at the theater prior to contest, Date/Time
Last Official activity: Completion of evals xxxxxxxxxxxxxxxx

Convention Chairman: Name xxxxxxxxxxxxxxxx
 Home: xxx xxx xxxx Email: xxxxxxxxxxxxxxxxxx

Judges Services Coordinator: Name xxxxxxxxxxxxxxxx
 Home: xxx xxx xxxx Email: xxxxxxxxxxxxxxxx

- 1. Mode Of Transportation**
- { } Round trip Coach Fare \$0000.00
 - { } Driving to/from airport 80 miles @ \$.25/mile \$0000.00
- *Note: Cost will be the lesser of the miles at \$20 or the cost of the lowest available airfare.
- Parking, tolls, shuttle, etc. (Specify) \$0000.00
- 2. Travel Information** (Please indicate arrival time even if driving)
- Arrival: Date xxxxxx Time: xxxx p.m. Airline xxxxxxxx
 Departure: Date: xxxxxx Time: xxxx a.m. Airline xxxxxxxx
 { } Host chapter will provide transportation to and from the xxxxxxxx airport.
- 3. Housing Information:**
- All rooms are non-smoking \$0000.00
 { } My wife/guest will not accompany me
 I understand that I am responsible for the additional room cost.
- 4. Other Expenses:** Meals: # Breakfast \$xxxx # Lunch \$xxxx # Dinner \$xxxx Meals:
\$0000.00
- Meals during travel: \$xxxx \$0000.00
 Baggage Handling and tips \$0000.00
 Other Expenses: (Specify) \$0000.00
 Computer Usage (CA/ACA) (#xxxx) \$0000.00

Total Allowable Expenses (Check will be mailed unless otherwise specified) \$0000.00

Approved by DRJC Name xxxxxxxxxxxxxxxx Date xxxxxxxx
 Approved by Convention Chairman Name xxxxxxxxxxxxxxxx Date: xxxxxxxx
 Convention Treasurer: Name xxxxxxxxxxxxxxxx Date: xxxxxxxx
 Check # issued # xxxxxx Date: xxxxxxxx

AS-14-SD SAMPLE



**FAR WESTERN DISTRICT
BARBERSHOP HARMONY SOCIETY**

2010

SPRING/DIVISIONAL 16 PAGE PROGRAM LAYOUTS

<p>5.5"</p> <p>(Possible Ads/Etc.) or Blank</p> <p>8.5"</p> <p>BACK COVER</p>	<p>(Year) Far Western District (FWD Logo) BARBERSHOP HARMONY SOCIETY</p> <p>SPRING (Int. Prelims) (Name) DIVISIONAL CONVENTION/CONTESTS (Dates) INT. PRELIMS QUARTETS CHORUS, QUARTET, SR. QUARTET SHOW OF CHAMPION</p> <p>(Auditorium Location-Address) (Headquarters Hotel) (Hosted By)</p>
--	---

Sheet 1 outside

<p>CONVENTION DEDICATED TO (Name) (Photo) <i>(Information on Dedicatee)</i></p> <p>_____</p> <p>_____</p> <p>_____</p> <p>_____</p> <p>-----</p> <p>INSIDE FRONT COVER Page 2.</p>	<p>Blank, Filler Or (Possible Ads/Etc.)</p> <p>INSIDE BACK COVER Page 15</p>
---	---

Sheet 1 inside

SPRING/DIVISIONAL 16 PAGE PROGRAM LAYOUTS

<p>QUARTET FINALS (Date-Time) MC (Name-Home)</p> <p>Mike Tester Qt. Tenor-Lead (Qt. Name) Bari-Bass</p> <p># ----- ----- # ----- # ----- ----- # ----- # ----- ----- <i>etc.</i></p> <p>Page 12</p>	<p>OFFICIAL PANEL OF JUDGES</p> <p>Contest Administrator (Name-Home) Assoc. Contest Adm. (Name-Home) <i>M u s i c (N a m e - H o m e)</i> (Name-Home) Presentation (Name-Home) (Name-Home) Singing (Name-Home) (Name-Home)</p> <p>EXPLANATION OF JUDGING</p> <p>MUSIC ----- ----- PRESENTATION ----- ----- SINGING ----- -----</p> <p>Page 5</p>
<p>QUARTET SEMI-FINALS (1) (Date-Time) MC (Name-Home)</p> <p>Mike Tester Qt. Tenor-Lead (Qt. Name) Bari-Bass</p> <p># ----- ----- # ----- ----- # ----- ----- # ----- ----- # ----- <i>etc.</i></p> <p>Page 6</p>	<p>QUARTET SEMI-FINALS (3)</p> <p># ----- ----- # ----- ----- # ----- ----- # ----- ----- # ----- <i>etc.</i></p> <p>ANNOUNCEMENT OF DIV. CHORUS CONTEST WINNERS</p> <p>1. ----- 2. ----- 3. ----- <i>etc.</i></p> <p>Page 11</p>

Sheet 3 Outside
Sheet 3 Inside

AS-17-SD **SAMPLE**



**FAR WESTERN DISTRICT
 BARBERSHOP HARMONY SOCIETY**

2010

FWD SPRING/DIVISIONAL SCHEDULE OF EVENTS

Thursday,

2:00 PM	FWD Board Meeting	Holiday Inn Select -Tejon room (2nd Floor)
7:00 PM	Registration - Open till 9:00 PM	Holiday Inn Select - Pre-Function Area
7:00 PM	FWD Board Meeting Continues	Holiday Inn Select -Tejon room (2nd Floor)
7:00 PM	Jump Start Barbershop	Holiday Inn Select - Beale Room

Friday,

9:00 AM	Registration - Open till 9:00 PM	Holiday Inn Select - Pre-Function Area
9:00 AM	Class TBD	Holiday Inn Select - Sumner Room
9:00 AM	AHSOW - To Midnight	Holiday Inn Select - Harvest room
10:00 AM	Barbershoppers Shop - Open till 7:00 PM	Convention Center - Truxtun Room
10:00 AM	Ladies Hospitality Room - No Host, All Day	Holiday Inn Select - Belridge Boardroom
11:00 AM	Hall of Fame Luncheon	Holiday Inn Select - Hammons Room
11:00 AM	Harmony For Lunch Bunch	Pizzaville USA, 700 Oak Street
12 Noon	Youth Hospitality Room (All Day)	Holiday Inn Select - Oleander
1:00 PM	YMIH Plan That Works	Holiday Inn Select - Baker Room
1:00 PM	House of Delegates Meeting	Holiday Inn Select - Habersfelder/Beale Rooms
1:30 PM	Sing & Be Coached By Q	Holiday Inn Select - Sumner Room
2:00 PM	Tag Singing Class With Dan McQuigg	Convention Center - Caliente Room
2:30 PM	Doors Open Quartet Senior Contest	Convention Center Auditorium
3:00PM	Chapter Counselors Meeting	Holiday Inn Select - Hammons Room
3:15 PM	Senior Contest	Convention Center Auditorium
3:15 PM	Tots TV Room - During Senior Contest	Concert Hall Lobby - Cotton Room
4:00PM	Buffet Dinner	Holiday Inn Select - Ball Room
5:00 AM	*Senior Quartet Evaluations	Convention Center Auditorium
6:00 PM	Doors Open Quartet Semi-Finals	Convention Center Auditorium
6:45 PM	Quartet Semi-Finals Contest	Convention Center Auditorium
6:45 PM	Tots TV Room - During Semi-Finals	Concert Hall Lobby - Cotton Room
10:45 PM	*Quartet Evaluations (Non-Finalists)	Holiday Inn Select - Judges Rooms 2nd Floor

* Approximate Time

Saturday,

8:30 AM	Q & A	Holiday Inn Select - Sumner Rooms
9:00 AM	Registration - Open till 8:00 PM	Holiday Inn Select - Pre-Function Area
9:00 AM	AHSOW - To Midnight	Holiday Inn Select - Harvest room
9:00 AM	Barbershoppers Shop - Open till 7:00 PM	Convention Center - Truxtun Room
9:15 AM	Mic Testing Chorus Vocal Tune-up	Convention Center - Arena, Photo Risers
9:30 AM	Doors Open Chorus Contest	Convention Center Auditorium
10:00 AM	Ladies Hospitality Room - No Host, All Day	Holiday Inn Select - Belridge Boardroom
10:15 AM	Small Chorus Competition	Convention Center Auditorium
10:15 AM	Tots TV Room - During Contest	Concert Hall Lobby - Cotton Room
2:00 PM	H. S. Quartet Contest	Holiday Inn Select - Oleander
3:30 PM	*Chorus Evaluations	Convention Center Auditorium
4:00 PM	Buffet Dinner	Holiday Inn Select - Ball Room
6:00 PM	Doors Open Quartet Finals	Convention Center Auditorium
6:45 PM	Quartet Finals Contest	Convention Center Auditorium
6:45 PM	Tots TV Room - During Finals	Concert Hall Lobby - Cotton Room
7:00 PM	Barbershoppers Shop Closes	Convention Center - Truxtun Room
9:00 PM	*Show Of Champions	Convention Center Auditorium
9:00 PM	Tots TV Room - During SOC	Concert Hall Lobby - Cotton Room
9:00 PM	*Finalist Quartet Evaluations	Holiday Inn Select - Judges Rooms 2nd Floor
10:45 PM	*Woodshed Quartet Contest	Holiday Inn Select - Sumner & Baker Rooms
10:45 PM	*Hospitality Rooms	All Over the Holiday Inn Select
	* Approximate Time	

Sunday,

8:30 AM	Long Range Planning Meeting	Holiday Inn Select - Sumner Room
8:30 AM	Evaluations Finalist Quartets	Convention Center - Truxtun Room
9:00 AM	Youth Activities Meeting	Holiday Inn Select - Beale Room
10:00 AM	Events Comm Meeting	Holiday Inn Select - Harvest Room

AS-18-SD SAMPLE



**FAR WESTERN DISTRICT
 BARBERSHOP HARMONY SOCIETY**

2010

SAMPLE CONVENTION SIGNAGE

All FWD Conventions will need a Signage person(s), who will work closely with all committees and make signs for any occasions where needed especially at Registration Area, Parking, Auditorium, etc. Use a computer to generate signs to save money. Signs will be needed for the following:

- a. Registration area , box identification etc.
- b. Large overhead signs for prices, instructions, hosts etc.
- c. Direction to all events.
- d. Individual quartet and chorus names
- e. Parking directions
- f. Billboard directions for public
- g.
- h. Non-singing areas of hotel

SIGNS NEEDED

Task	Completed
Some of The following signs are needed because of District Policy of having registration badges with you at all times. Others are just plain courtesy on your part as host. Check with GCC to see if he has any special signs that may be needed.	
‘ REGISTRATION AREA (A-D, E-H etc.) - One for each station, check with registration person on how many people he will be using.	
‘ SIGN-IN TABLE FOR QUARTETS AND CHAPTER REPS. - A table should be set up by the contestant dressing area where quartets and chapter reps. should sign-in and get information where dressing area is, time sheets etc.	
‘ QUARTET AND CHORUS DRESSING AREA - One sign for each competing quartet and chorus to be located on door or in area to dress.	
‘ JUDGES ROOM - One sign to be put on judges room door.	
‘ NO SEATING BEYOND THIS AREA (where applicable) - One or two signs for blocked off area behind judges pit (one row of seats) or first row.	
‘ NO TALKING BEYOND THIS POINT - Make up at least 2 of these signs for outside and inside of stage door.	
‘ WARM-UP ROOM	
‘ READY ROOM	
‘ ALL CONTESTANTS MUST HAVE REGISTRATION BADGES WITH THEM AT ALL TIMES. Make up at least 2 of these signs for the dressing area.	
‘ PLEASE SHOW REGISTRATION BADGE BEFORE ENTERING STAGE. - Make up one sign for outside of entrance to stage.	
‘ NO ONE WILL BE ALLOWED IN AUDITORIUM WITHOUT REGISTRATION BADGE – Make up one sign for lobby area or for each entrance door into auditorium.	
‘ QUARTET AND CHORUS CONTACT SIGN-IN TABLE - Make up one sign for lobby area and one for dress room area.	

AS-19-SD SAMPLE



**FAR WESTERN DISTRICT
 BARBERSHOP HARMONY SOCIETY**

2010

SAMPLE EXPENSE VOUCHER

(PLEASE ATTACH RECEIPTS AND OTHER PERTINENT INFORMATION)

To: (Name)

General Mgr./Convention Manager

Request for reimbursement for necessary expenses incurred pursuant to my duties in performance

Date	Item	Description	Total

of the (Year) FALL Convention/Contests.

TOTAL	\$
Approval By: _____ (Committee Chairman) (General Mgr./Convention Chairman)	
Mail Check to: _____	
Street Address: _____ City: _____ State: _____ Zip: _____	
Date Paid: _____ Check No. _____	
Remarks:	



**BARBERSHOP HARMONY SOCIETY
SPEBSQSA, Inc.**

FAR WESTERN DISTRICT

**PART C - SECTION 1
SPRING/DIVISIONAL
CONVENTIONS/CONTESTS**

**THEATER
EXHIBIT GUIDES**

TG-01



**FAR WESTERN DISTRICT
BARBERSHOP HARMONY SOCIETY**

2010 THEATER
TECHNICAL REQUIREMENTS
ALL CONVENTIONS/CONTESTS

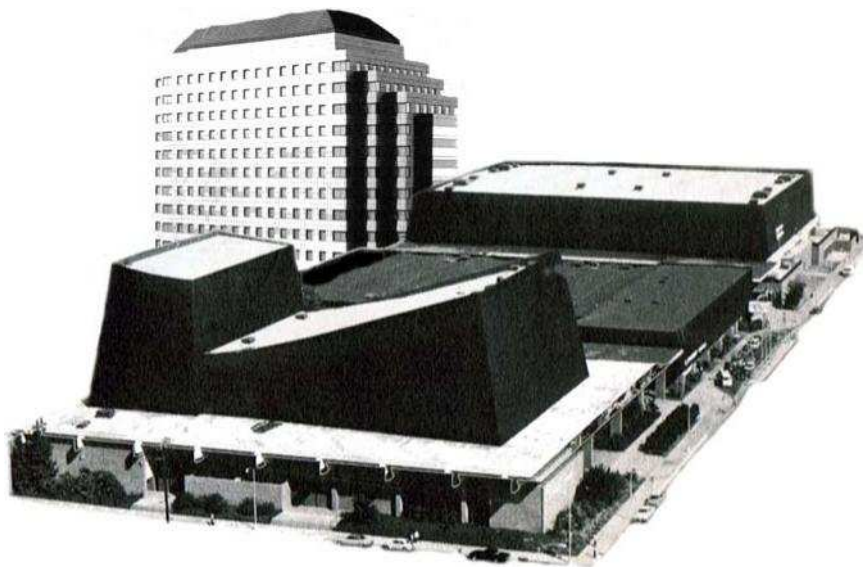

**Far Western District
CONVENTION REGULATIONS MANUAL**

REVISED March 1, 2009

Doug Maddox/Fritz Grunenwald

FWD Convention Manual Administrators

THEATER

TECHNICAL REQUIREMENTS

This document specifies typical technical requirements for the Barbershop Harmony Society, Inc. contest sessions. These requirements may have to be modified to deal with the capabilities and/or constraints of various contest venues. Compromise is possible, but the technical arrangements for any specific convention must be approved by the FWD Chairman of the Events Committee, and the Convention General Manager. For the Spring and Fall District Conventions, approval is required from the FWD Production Director as well.

I Stage/Rigging [Refer to supplied sketches]

- A. Supply a full complement of legs and borders, preferably black
- B. If at all possible, the main curtain should travel rather than fly
- C. Supply a speaker's podium DSR with reading light
- D. Client will arrange for choral risers, and choral shell.

II. Lighting

A. Areas [refer to supplied sketches]

- 1. Chorus General
 - a. Light entire stage from front edge of apron to top man on top row of choral risers.
 - b. Front: Shoot from FOH and 1st elec, no color OK, maximize footcandles.
 - c. Down: Shoot from 1st and 2nd elec, lt. blue and lt. pink for tone
 - d. Cross: Shoot from box booms or coves, lt. blue and lt. pink for tone.
- 2. Quartet Center Area (10 to 12 foot circle centered on mic).
 - a. Front: Best FOH position, two instruments center (no color), two off-left (lt. blue), two off-right (lt. pink).
 - b. Cross: Box boom or cove position, one or two instruments each side (lt. blue, lt. pink).
 - c. Down: 1st electric, two instruments (lavender)
 - d. Side: 1st electric, one instrument each, way off left and right (lavender).
- 3. Bow Lights: This is essentially the remainder of the apron off-left and off-right. Used during Quartet Events, when Main curtain is in (or in the "Quartet Configuration") during quartet entrances and exits and when they spread out during applause between selections.
- 4. Judging Area (orchestra pit), appropriate number of instruments.
- 5. Speaker Special, on podium, usually DSR, two instruments from appropriate FOH position.
- 6. Curtain Warmers [optional] (whatever you think).

B. Control

- 1. Each area listed above on a separate submaster (or equivalent)
- 2. Control from backstage rather than FOH is convenient, but not required.
- 3. Convenient House light control

C. Infrastructure

Sufficient dimmers, cable runs, twofers, gel, gel frames, spare lamps, safety equipment, etc. to support the above

III. Audio See [Refer to

Sound System Guidelines]

A. Input Channels

1. Chorus: 3-4 flown condensers [Audiotechnica 4051a or equivalent] (no floor stands permitted) Height approx. 10 to 12 feet. The axis should be between horizontal and 45 degrees down, but **NOT** pointing directly at the floor.
2. Quartet Center: Two large-diaphragm condensers [Audiotechnica 4051a or equivalent] on a stereo bar on a single floor stand, downstage center. Placement angle 110-120 degrees, tails out (nose-to-nose).
3. Podium

B. House Mains

The nature of our music demands a system with superior frequency response and particularly wide dynamic range. Our audience is discerning and quite critical. Please make every effort to provide excellent sound. Do not compromise house sound quality without authorization from FWD Production Director.

C. Stage Monitors

A pair of wedge monitors down stage of the Quartet Center mike cluster, fed by a separate monitor mix.

D. Backstage Monitors

SR (additional monitor SL preferable but optional), nothing special, small utility monitor, with local level control if possible, fed by the house mix..

E. Separate Recording Mix

1. Stereo cassette deck for educational/archival recording, one cassette per competitor. This deck can be operated by client-supplied personnel. Location is variable, but is generally done at a large table backstage.
2. Additional stereo deck (digital, if available) for archive copy of each event in its entirety.

F. Mono Feed

Recording mix suitable for input to video camcorder (appropriately low level), location to be determined following site visit.

G. Production Communications

Headset stations at all appropriate locations

H. Infrastructure

Adequate console, sufficient microphones, speaker arrays, power amps, outboard processors, cable runs, mike stands, shock mounts, etc. to support above

I. Choice of operator

This is not rock and roll, but more like orchestral (our choruses), and chamber music (our quartets). It can be very powerful as well, while, at the same time, quite sensitive. Performer-to-microphone distances are relatively large.

J. Important Operation Note

The first act in each event is usually a "mike-tester" competitor. Their performance is used to set levels. They will stay on stage until the levels in the house and in the judging area are acceptable to the Contest Administrator (Chairman of Judges). When he approves, the levels and EQ are set (**NOT** to be changed) for the balance of that contest session. The podium level may be freely adjusted as needed.

IV. Judging Area

Usually, the orchestra pit or audience floor immediately in front of the stage.
[Refer to requirements for tables, chairs, etc. specified in a separate document.]

A. Supply

Always-hot AC power outlets at frequent intervals for client-supplied task lighting. Think of this as supplying AC for 20-30 music stand lights in the orchestra pit. Two or three of these outlets, usually far stage right corner of the pit, are for computer equipment and should be on a circuit separate from the lights.

V. Sequence of Events

There are basically two types of events during the Convention: Quartet events and Chorus events. Events of either or both types are grouped into shows. The actual schedule for any convention may vary.

A. Quartet Event

A sequence of competing quartets, each performing two selections, separated by remarks from an emcee at the podium. A sequence of lighting and audio cues will be repeated for each competitor.

B. Chorus Event

A sequence of competing Choruses, each performing two selections, separated by main curtain close, remarks from an emcee at the podium, and a main curtain open. A sequence of curtain, lighting and audio cues will be repeated for each competitor.

VI. Typical Basic District Spring Convention Show Schedule

A. Friday

1. Load-in
 - a. Set up choral risers
 - b. Hang, focus lighting
 - c. Hang, set up audio
 - d. Change to quartet configuration
 - e. Adjust if necessary
 - f. Assist set up of judging area
2. Break for supper
3. Friday night show
 - a. Quartet event
 - b. Remarks by VIPs
4. Change to Chorus configuration

B. Saturday Morning

1. Saturday morning show
 - a. Small chorus event
 - b. Remarks by VIPs
2. Change to Quartet configuration

C. Saturday Mid-Morning

1. Saturday mid-morning show
 - a. High School Quartet event
 - b. Remarks by VIPs
2. Break for lunch

D. Saturday Afternoon

1. Saturday afternoon show
 - a. Quartet event
 - b. Remarks by VIPs
2. Change to configuration for evening show
(the evening show which starts with quartet event,
but includes one or more chorus appearances)
3. Break for supper

E. Saturday Evening

1. Saturday evening show
 - a. Quartet event
 - b. Remarks by VIPs
 - c. One or more chorus appearances
 - d. More quartet appearances
 - e. Possible load-out

F. Sunday Morning

1. Finish any remaining load-out

VIII. Typical Basic Divisional Convention Show Schedule

A. Saturday Morning

1. Load-in
 - a. Set up choral risers
 - b. Hang, focus lighting
 - c. Hang, set up audio
 - d. Change to quartet configuration
 - e. Adjust if necessary
 - f. Assist set up of judging area
2. Break for lunch

B. Saturday Afternoon

1. Saturday afternoon show
 - a. Quartet event
 - b. VIPs remarks
2. Change to configuration for evening show
(the evening show which starts with chorus event, but includes one or more quartet appearances and then final chorus appearance)
3. Break for supper

C. Saturday Evening

1. Saturday evening show
 - a. Chorus event
 - b. Change to quartet configuration
 - c. Remarks by VIPs
 - d. Quartet appearances
 - e. Change to chorus configuration
 - f. Chorus appearance
 - g. Load-out

VII. Typical Basic District Fall Convention Show Schedule

A. Friday

1. Load-in
 - a. Set up choral risers
 - b. Hang, focus lighting
 - c. Hang, set up audio
 - d. Change to quartet configuration
 - e. Adjust if necessary
 - f. Assist set up of judging area
2. Break for supper
3. Friday night show
 - a. Quartet event
 - b. Remarks by VIPs
4. Change to Chorus configuration

B. Saturday Morning

1. Saturday morning show
 - a. Chorus event
 - b. Remarks by VIPs
2. Change to Quartet configuration
3. Break for lunch

C. Saturday Afternoon

1. Saturday afternoon show
 - a. Quartet event
 - b. Remarks by VIPs
2. Change to configuration for evening show
(the evening show which starts with quartet event, but includes one or more chorus appearances)
3. Break for supper

D. Saturday Evening

1. Saturday evening show
 - a. Chorus appearance
 - b. Quartet appearances
 - c. Chorus appearance
 - d. Remarks by VIPs
 - e. Chorus appearance
 - d. More quartet appearances
 - e. Chorus appearance
 - f. Remarks by VIPs
 - g. Possible load-out

E. Sunday Morning

1. Finish any remaining load-out

- End of Tech. Guide -

TG-02



**FAR WESTERN DISTRICT
BARBERSHOP HARMONY SOCIETY**

CONTESTS – ALL CONVENTIONS

MICROPHONE AND SOUND SYSTEM GUIDELINES

Written by Glen Glancy and Bill Lightner
Edited by Doug Maddox

This document establishes a common source of microphone and sound system guidelines for the members of the Society. These guidelines provide

- A level of understanding and confidence for discussing microphone and sound system requirements for quartets and chorus groups with venue and contract sound engineers. You will know why to ask for specific equipment and setups as well as what to ask for.
- A consistent microphone and system design technique to be used at local, area, and district level events.

The Microphone

The beginning of the sound system chain is the microphone. No sound system can make up for poor microphones, and no show—whether it is held in the local grange hall or on the international championship competition stage—will provide a fair representation of the talents of the performers to the audience without good microphones.

Microphone Recommendations

Any reasonably large city will have an audio rental company that will provide – via UPS if necessary – rental microphones of studio quality. Rental rates vary, but you can expect to pay between ten and twenty dollars per microphone per day of usage. You do not pay for the time during which the microphones are in transit, only when they are in use.

The following lists provide the names of commonly available small diaphragm cardioid condenser microphones, which are suitable for use with both quartets and choruses. We do not recommend large diaphragm condenser microphones – the choice for vocal recording – for SPEBSQSA events. When floor monitor speakers are used at the singing position, the typical loss of pattern control at low frequencies in these microphones results in feedback. In simple terminology, the monitors cannot be loud enough to be of benefit to the performers before the sound from the monitors, is picked up by the microphones and re-amplified, causing what is known as feedback. Small diaphragm microphones provide better low frequency pattern control and therefore can be used successfully with floor monitor speakers.

Recommended Microphones

"A" List	"B" List
Sennheiser MKH 40	AKG C391B
AudioTechnica 4051a	AKG C460-CK61 or 480-CK61
Schoeps MK4	AKG C451E
Neumann KM140	Shure SM81
Neumann KM 84	
Neumann KM 184	

Quartet Microphone Setup

A pair of the same microphones, such as two Sennheiser MKH40's, should be mounted to a single mic stand using a device called a "stereo bar." A stereo bar is a simple flat bar that attaches at the center of a standard mic stand and has a slug at each end for attaching a standard mic clip to the bar. Microphones attached in such a manner can then be aimed by adjusting the clips to point the capsules in relationship to the performers.

Choosing a Mic Stand

If the stage is a permanent one, we recommend an Atlas Soundolier MS25 stand with a boom attachment. This is a heavy-duty stand with a tripod-shaped heavyweight cast iron base. It is capable of supporting the microphones on a boom without additional weights to hold the stand in place. The boom attachment places the vertical portion of the stand out of the way of hand gestures by the performers. Straw hats, canes, and other props have a knack for finding their way against a mic stand.

If the stage is a temporary one, we recommend an Atlas Soundolier BS36 stand placed on the solid floor in front of the stage, weighted if necessary, and extended to place the microphones on a boom at stage height. You have seen this method used for the past several years at Internationals. It keeps the stage noises caused by performer movement from being picked up mechanically through the stand.

Aligning the Microphones

The microphones should be at mid-chest height for a "standard" six-foot barbershop singer or higher. The microphones should be adjusted so the **capsules** are at the same point in space, perfectly aligned vertically with one atop the other, and as close as possible without the microphone bodies touching each other (Figure A). Since you can actually see the capsules on most of the microphones we recommend, this should be easily accomplished before placing the windscreens on the mics.

When viewed from the top, looking down at the mics (Figure B), the capsules should create a pickup radius of about 180 degrees horizontally. So, if you begin with the capsules 90 degrees to each other and increase that angle by moving the capsules another 15 degrees each, you should be close to correct. The capsules should appear to crossfire and aim at quartet singing positions one and four. Only mic tests, which are described later, will confirm the accuracy of the alignment.

FIGURE A

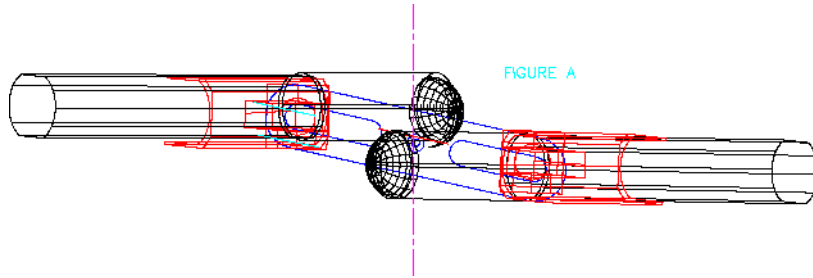
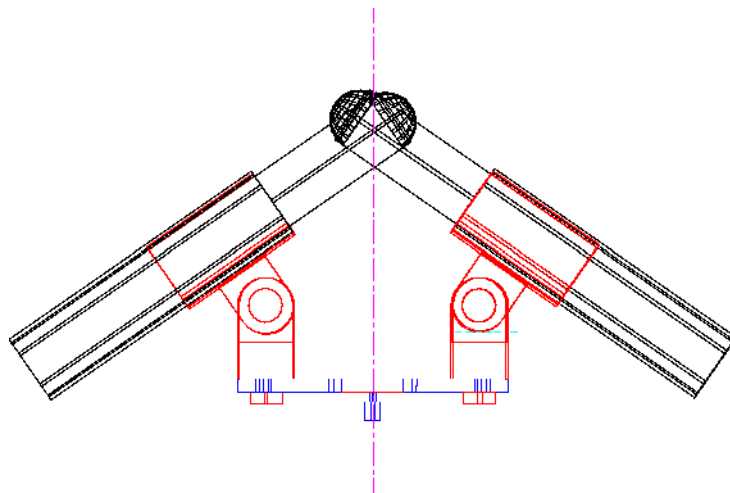

FIGURE B



Marking the Toe-Line Radius

The next essential step – critical in competition but proper for shows as well – is to mark a standard radius on the floor that the performers are not allowed to cross. This “toe-line” radius should be approximately 36 inches from the center point of the microphone setup. Mark the floor with white tape or some other highly visible method that the performers will be able to see even with stage lights in their eyes.

Placing the Floor Monitor Speakers

Floor monitor speakers should be placed behind the microphones, between the lip of the stage and the rear of the microphone array. Place the speakers as close to the vertical mic stand as possible, angled out to face the performers. One speaker should serve performers one and two, and the other should serve performers three and four.

The speakers should project sound toward the least sensitive area of the microphone pattern. With cardioid microphones, the least sensitive area is the backside of the capsule; therefore, you would aim the speakers at the tail of those microphones. Slight adjustments may be necessary to find the best sound gain before feedback, but generally this location will serve the needs of the performers. Adjustment of monitor EQ will be necessary to maximize available gain before feedback.

Testing the Microphones

The off-axis pattern variations of the microphones are sufficiently different to require the following steps, although the setup may appear to match the preceding instructions. Perform the following steps to test the microphones:

1. A single person, a *talker*, should alternately stand at quartet singing positions one and four, speaking directly on axis to each of the microphones, while the sound system operator adjusts the signal levels to match when heard in the house speakers. An appointed *listener* should be in the house to confirm this matching process.
2. The talker should stand exactly between the microphones and, while speaking, move his head within a one-foot side-to-side distance to assure that no coloration of the sound occurs between the pickup of the two microphones. This sound variation is caused by “phasing,” which is a time Domain problem between the two capsules.

To fix a phasing problem, move one microphone along its own axis, in towards the other microphone or out away from the other microphone, until no “seam” in the coverage area can be discerned. It is important to retain the angle of the capsules to each other and move only the relationship of the capsules in the horizontal plane. The mechanical center between two microphones and the acoustical center between them may not be the same due to the physical makeup and construction of the particular microphone model. This is a result of construction techniques employed to tune the pickup pattern to the manufacturer’s design criteria.

3. Confirm that this pair of microphones picks up all four voices with equal level. The talker should speak into the mics while moving around the toe line through the four singing positions. The listener should perceive no apparent level difference for those four positions.

To verify the mic levels

- If the two outside singers appear to be louder than the two center singers, reduce the angle of the mics from the 110-120 degree setup to a setup closer to 90 degrees.
- If the center singers are too loud, increase the angle of the mics beyond the 120-degree point. This is a subtle adjustment. A couple of degrees will make a difference. Be sure to re-check the center pickup point if you have to make this change.

Proper setup and testing will result in a microphone array that will provide an accurate and sonically awesome representation of the quartet's barbershop sound that will both interface with a mono sound reinforcement system and also provide an excellent stereo pickup for recording.

Quartet Sound System Setup

We recommend that you bring a quartet or chorus recording with which you are very familiar to the venue and play it back over the system. To adjust the sound system, perform the following steps:

1. Walk throughout the seating areas and listen to how the system reproduces the music. This procedure is also advisable for selecting a venue for a barbershop performance.
2. After comparing the sound of the disc as you know it to how the music sounds in the hall, ask the sound system operator to make any necessary equalization adjustments – bass and treble control changes – on the CD input modules of the mix console until the recording sounds correct. Explain to the system operator that you want the live show sound to have the same tonal qualities.
3. Find a willing and capable quartet to test the mics. Have them take the marked positions and sing while you and the system operator fine tune the sound. Take your time doing this. Make small adjustments until you are satisfied.
4. Make it clear to all concerned that the system is not to be further adjusted by anyone before showtime. Final system tuning is best done when the hall is full, as described next.
5. When the audience is in place, you may find that the overall sound level control will have to be increased to compensate for the changes in acoustics that result from the hall being full of people. Small changes in equalization may also be necessary.
6. While you have a quartet on stage to sing, you should arrange to have either the Contest Administrator or his designated representative involved in the final system tuning process. This cooperative effort should assure that the panel would accept the competition mic tester performance with little or no request for further adjustment of the sound system.

Chorus Microphone Setup and Sound System Tips

The microphones listed earlier in this document also can be used for reinforcement of a chorus.

Placing the Chorus Microphones

Three to five microphones should be used, depending on the size of the chorus. These mics should be hung six to eight feet in front of the front edge of the first riser step, and in an arc matching that of the risers. Proper hanging height places the capsule slightly above the heads of singers standing on the top row of the risers. The axis of the microphone should be aimed down at the mouths of singers on the middle row of risers.

When choruses perform all or a portion of a selection off the risers, we recommend that microphones designed to be placed on a flat horizontal surface, such as the Crown PCC 160, be used at the lip of the stage. For example, when choreography is part of the stage presentation, these microphones will assist in retaining the full choral sound while the group is away from their riser positions. Place three microphones at the lip of the stage, one in the center and two others spaced eight feet on each side of center, all three placed eighteen inches upstage from the lip.

Testing the Chorus Microphones

Follow the same guidelines as for the Quartet Microphone Setup.

1. Make sure that a talker walks the risers from end to end while a listener helps the sound operator adjust the microphone levels until they are matched in the house.
2. Listen to a known CD source and adjust the sound in the house so the sound system operator knows your goal for finished sound.
3. Proceed with a thorough sound check with a mic tester chorus. Take the time to make the adjustments required.
4. Arrange for the Contest Administrator or his designee to be present and to assist in the final settings.

BARBERSHOP HARMONY SOCIETY
FWD CONVENTION/CONTESTS CHORUS - MICROPHONE PLACEMENT

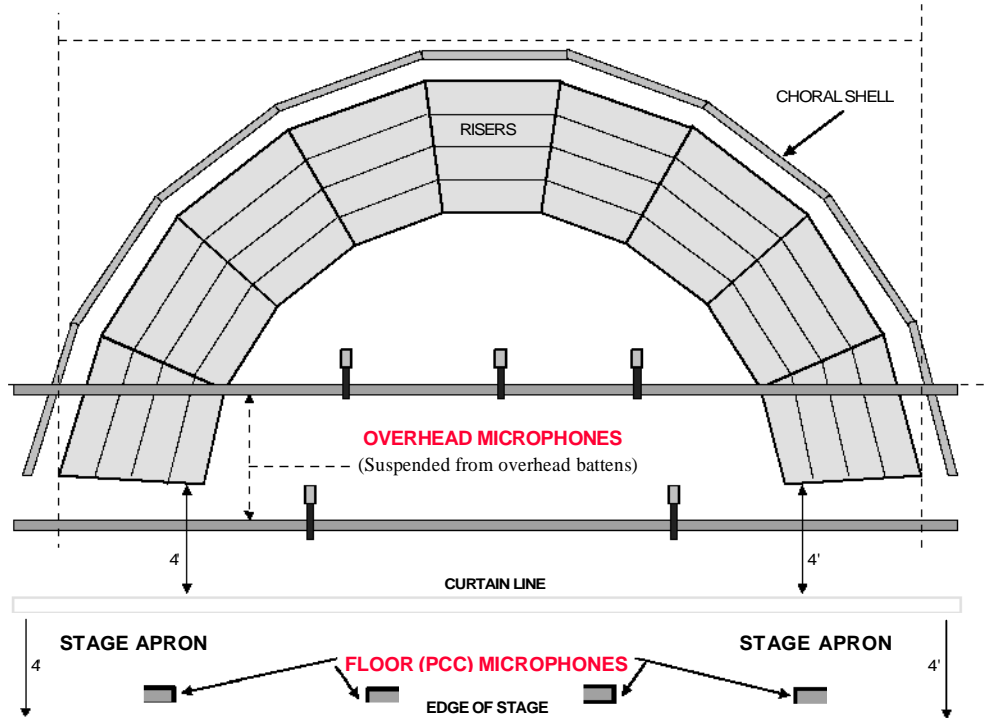

**BARBERSHOP HARMONY SOCIETY
FWD CONVENTION/CONTESTS
QUARTET MICROPHONE/MONITOR PLACEMENT
CONFIGURATION**

NOTE: Monitors will be less prone to feedback problems if positioned so as to shoot into back ("dead") side of mic.

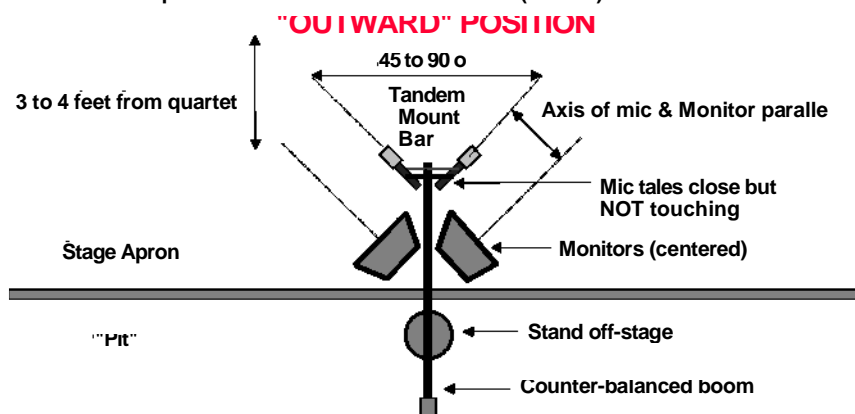

FIGURE 1.

QUARTET MICROPHONE/MONITOR PLACEMENT

NOTE: Monitors will be less prone to feedback problems if positioned so as to shoot into back ("dead") side of mic.

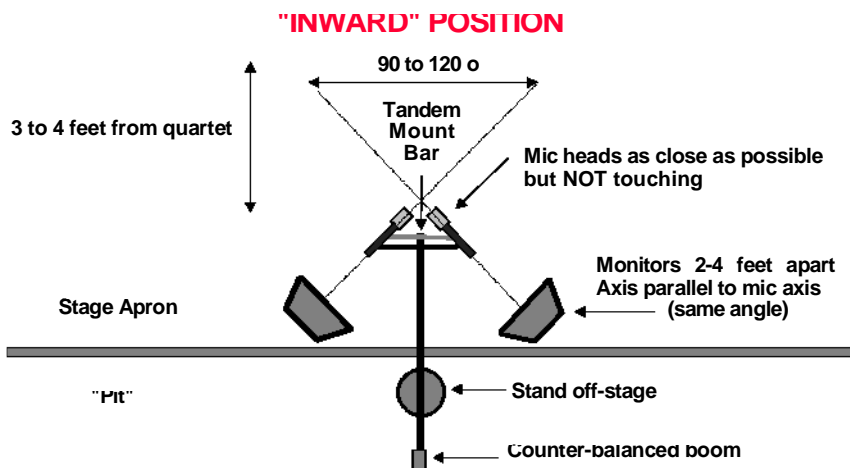
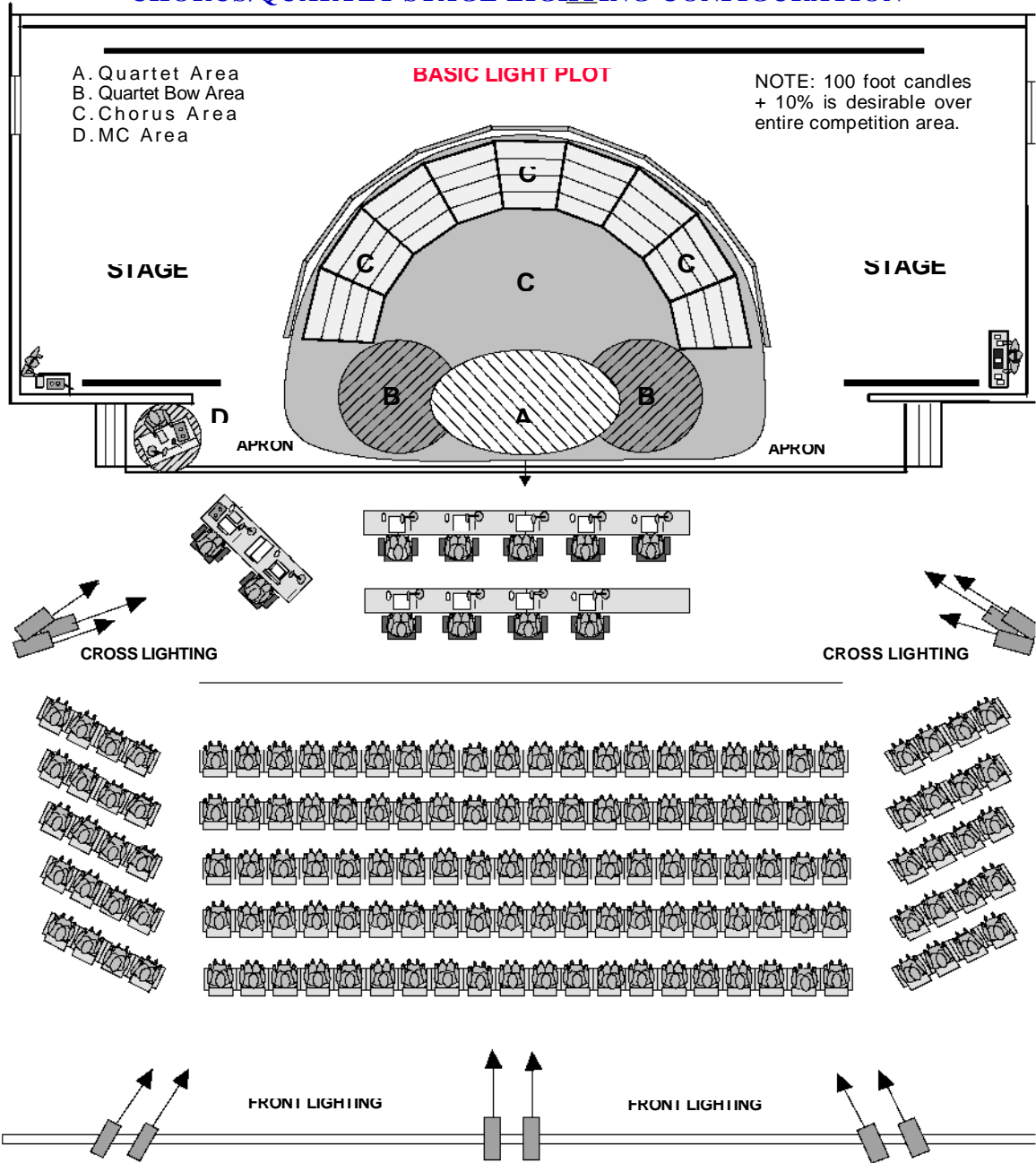

FIGURE 2.

-End of Sound Guide-

TG-03

**BARBERSHOP HARMONY SOCIETY
FWD CONVENTION/CONTEST
CHORUS/QUARTET STAGE LIGHTING CONFIGURATION**



TG-04



2009

ALL CONVENTIONS - STAGE GLOSSARY

APRON OR FORE STAGE: The section of stage between the front curtain and the audience.

BACKDROP: A large canvas, painted as a scene or wall, hung as the back element of a setting. Seldom used in this form now except in revivals. Shorter term: Drop.

BACKING: A flat or drop placed behind doors, windows and other openings in a set to mask the backstage from view of the audience.

BORDERLIGHT: The long strips of lights hung from side to side of the stage above the setting.

CIRCUIT: The electrical outlets or lights which are controlled by a single fuse.

COUNTERWEIGHT SYSTEM: An arrangement of lines, battens and weights found on well—equipped stages which is used to raise and lower scenery.

CURTAIN LINE: The place where the front curtain touches the stage floor.

DIMMER: Electronic or mechanical device for controlling the volume of light, which may be dimmed “up,” “down,” or “out.”

DOWN STAGE: This was originally used when stages actually slanted down toward the footlights. Now we mean toward the curtain line.

DUTCHMAN: A strip of wallpaper or cloth used to cover the crack between two flats. It is, of course, applied before painting.

ELLIPSOIDAL SPOTLIGHT: The ellipsoidal mirror, which increases the light output, gives the name to this unit, which also has movable shutters, which control the shape of the light beam.

FALSE OR INNER PROSCENIUM: A proscenium built inside the regular proscenium for a particular production, sometimes made in unusual shapes.

FLATS: Wooden frames covered with cloth.

STAGE GLOSSARY Cont.

FLOODLIGHT: A lighting unit which holds a large bulb, one thousand or more watts, used to flood an area with light. It cannot be focused. Also called an OLIVETTE.

FOOTLIGHTS: A strip of lights across the stage in front of the main curtain, of no real use in modern lighting.

FRESNEL: A spotlight, which has a fresnel, or ribbed lens.

GELATIN: A thin sheet of gelatin or plastic placed in frames in front of lighting units to change colors. Also called a GEL.

GRIDIRON or GRID: The framework of wooden or steel beams near the top of a stage house in which the rigging for raising or lowering scenery is mounted.

GROUND ROW: A long, low piece of scenery, usually representing hills or a wall in an exterior setting and placed to mask the bottom of a cyclorama or backdrop.

HAND PROPS: Those properties which actors carry on or off stage during the business of the show. Also called PERSONAL PROPS.

HEADS UP: A warning to look up, usually called out to anyone on stage when scenery is being raised or lowered.

HOUSE LIGHTS: All the lights in the auditorium except the exit lights. These are controlled from the light booth.

JOG: A narrow flat, one or two feet wide.

LASHING: Fastening two flats together with a lash line.

LASH LINE: The quarter-inch diameter sash cord used for lashing flats together. It should be of good quality.

LASH LINE CLEAT: The stage hardware around which the lash line is hooked when fastening flats together.

LEFT STAGE and RIGHT STAGE: Directions backstage are made from the actor's viewpoint as he faces the audience. Right stage is the actor's right, the audience's left.

LEG or LEG DROP: Pieces of cloth, usually six to ten feet wide, most often hung in pairs at stage right and left.

LINES: The ropes usually hung in sets of three, which run up to the gridiron and then down to the pin rail, used to raise and lower scenery.

LONG LINE: The longest of each set of lines, the one which goes to the floor on the side of the stage opposite the pin rail. The other two are, of course, the MIDDLE LINE and the SHORT LINE.

MASKING: To place flats or drops outside a setting so that the audience cannot see backstage through openings or above the set.

OFF STAGE: The stage outside the acting area, not visible to the audience.

ON STAGE: The acting area, visible to the audience. Also used as a command to come on stage.

STAGE GLOSSARY Cont.

OUT FRONT: In the auditorium.

PIN RAIL: A fixed steel or wooden beam placed either in the fly gallery or on the stage floor at one side. Here the lines used to raise and lower scenery are tied or, in the case of a counterweight system, locked.

PROPERTY TABLE: One or more tables placed behind the setting, most often near entrances, on which hand properties for the scene can be placed so the crewmember can hand them to the players at the right time.

PROSCENIUM: The architectural frame, which separates the stage from the auditorium. The proscenium is the frame itself while the PROSCENIUM OPENING is the space inside the frame.

RESISTANCE DIMMER: A mechanical device to control the volume of electricity reaching a stage lighting unit. Though not as efficient as the newer electronic and transformer dimmers, the resistance dimmer is still used on many stages.

RIGGING: The pulleys attached to the gridiron and the lines, which run through them to the pin rail and to the battens.

RUN-THROUGH: A term meaning to take a scene, act, or the entire shows straight through without interruption.

SET PIECES: Pieces of scenery, usually fairly small, which stand by themselves to depict walls, rocks, shrubs, distant hills, etc.

SETTING: The complete arrangement of scenery, furniture, properties and lighting used in the production.

SIGHT LINES: The lines of vision from the extreme sides of the auditorium.

SPATTERING: A painting technique, which adds texture to a flatly painted surface with dots of other colors.

SPOTLIGHT: A lighting instrument with concentrated light, which can be focused through a lens. It is usually mounted on a pipe batten but can also be mounted on a stand. It is for specific lighting of a particular portion of the acting area.

STAGE BRACE: An adjustable brace with a hook at one end which fastens into a brace cleat on the back of the flat and a foot-iron on the other end which is fastened to the floor with a stage screw.

STAGE CREW: The production staff of a show.

STAGE MANAGER: The person in charge of running the production during run-through rehearsals and performances.

STAGE SCREW: A metal screw with a sharp pitch, and a handle with which it is turned into the stage floor.

STRIKE: The order to remove from the playing area, properties, furniture, a light or the entire setting.

SWITCHBOARD: The master control panel through which the electrical circuits run. Here the dimmers control the volume of light. also called the LIGHTBOARD.

TEASERS: The special first cloth border just back of the spotlight battens. With the tormentors at right and left, it forms an inner frame for the stage opening.

TIE-OFF: To tie fast the hauling lines to the pin rail or to tie the lash line fastening two flats together.

STAGE GLOSSARY Cont.

TORMENTORS: A pair of flats, usually black, at the sides of the stage, just back of the proscenium opening. With the teaser, they form the inner frame. Also referred to as the FALSE PROSCENIUM.

TRACK: The track on which a traveller curtain works to open and close.

TRAVELLER: A stage curtain, which opens in the middle and is pulled to the sides of the stage.

TRIM: The process of adjusting a border or other hanging scenery, to get it into exact position.

UP STAGE: The direction away from the curtain line and also the areas farthest from the curtain line.

WINGS: The space outside the acting area on both sides of the stage. Also two pieces of scenery hinged so that they will stand at an angle. They are used in pairs at either side of the stage to mask offstage areas.

-End of Stage Glossary-

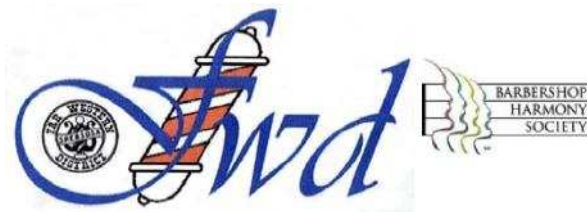

**BARBERSHOP HARMONY SOCIETY
SPEBSQSA, Inc.**

FAR WESTERN DISTRICT

**PART C - SECTION 2
SPRING/DIVISIONAL
CONVENTIONS/CONTESTS**

**THEATER
EXHIBITS**

TE-01

**BARBERSHOP HARMONY SOCIETY
FWD CONVENTION/CONTESTS
11 RISER CHORUS CONFIGURATION**

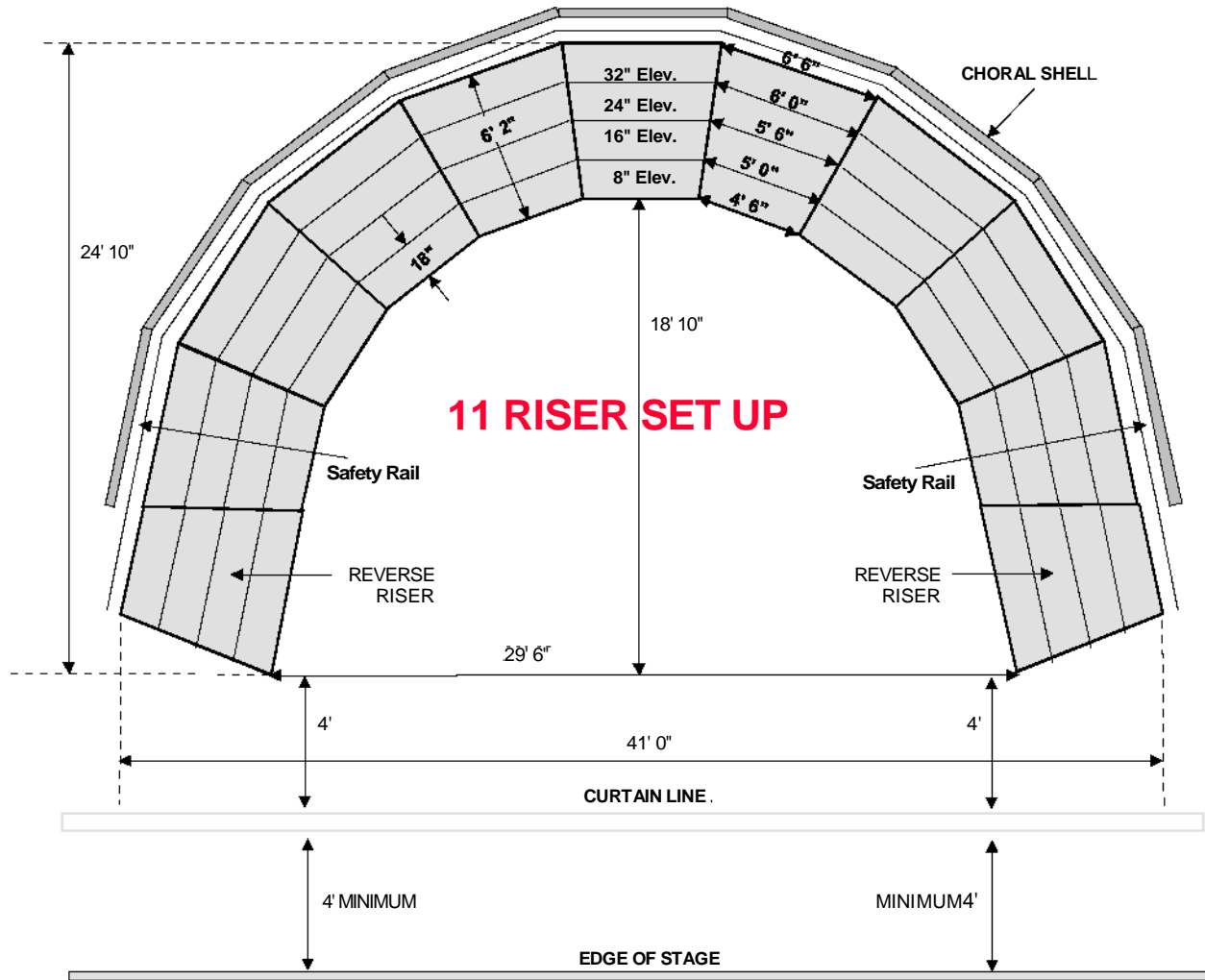

SET-UP FOR 11 - 6' RISERS INCLUDING FOURTH STEP & SAFETY RAILS
ACCOMMODATES 115 - 125 + CHORUS MEMBERS

BARBERSHOP HARMONY SOCIETY FWD CONVENTION/CONTESTS

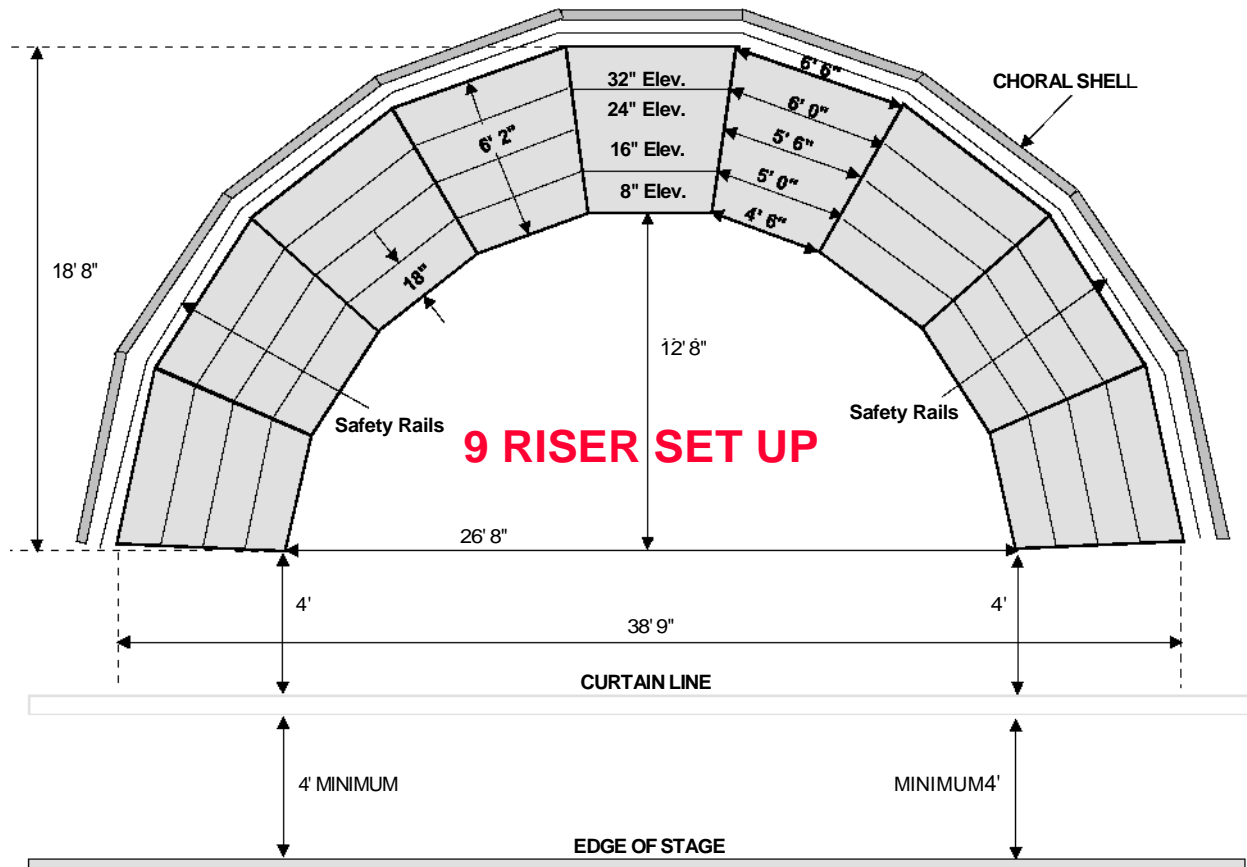

9 RISER CHORUS CONFIGURATION

SET-UP FOR 9 - 6' RISERS INCLUDING FOURTH STEP & SAFETY RAILS
ACCOMMODATES 95 - 105 + CHORUS MEMBERS

BARBERSHOP HARMONY SOCIETY FWD CONVENTION/CONTESTS 5 RISER CHORUS CONFIGURATION

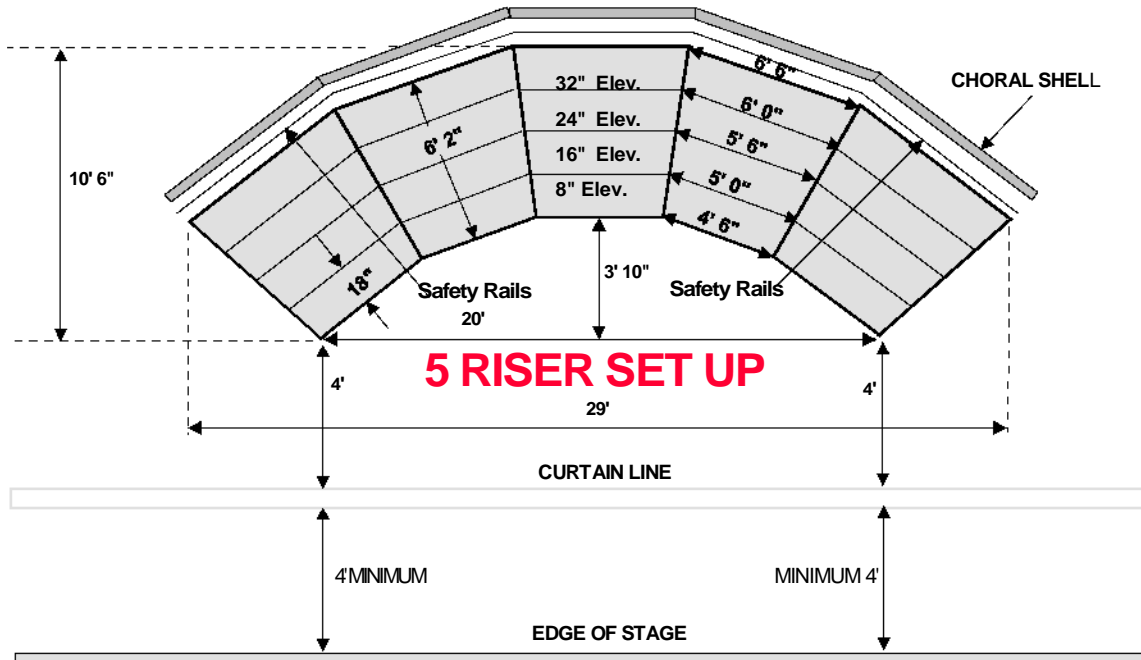

SET-UP FOR 5 - 6' RISERS INCLUDING FOURTH STEP & SAFETY RAILS
ACCOMMODATES 55 - 65 + CHORUS MEMBERS

-End of Riser Set-Up-

TE-02

BARBERSHOP HARMONY SOCIETY
FWD CONVENTION/CONTESTS

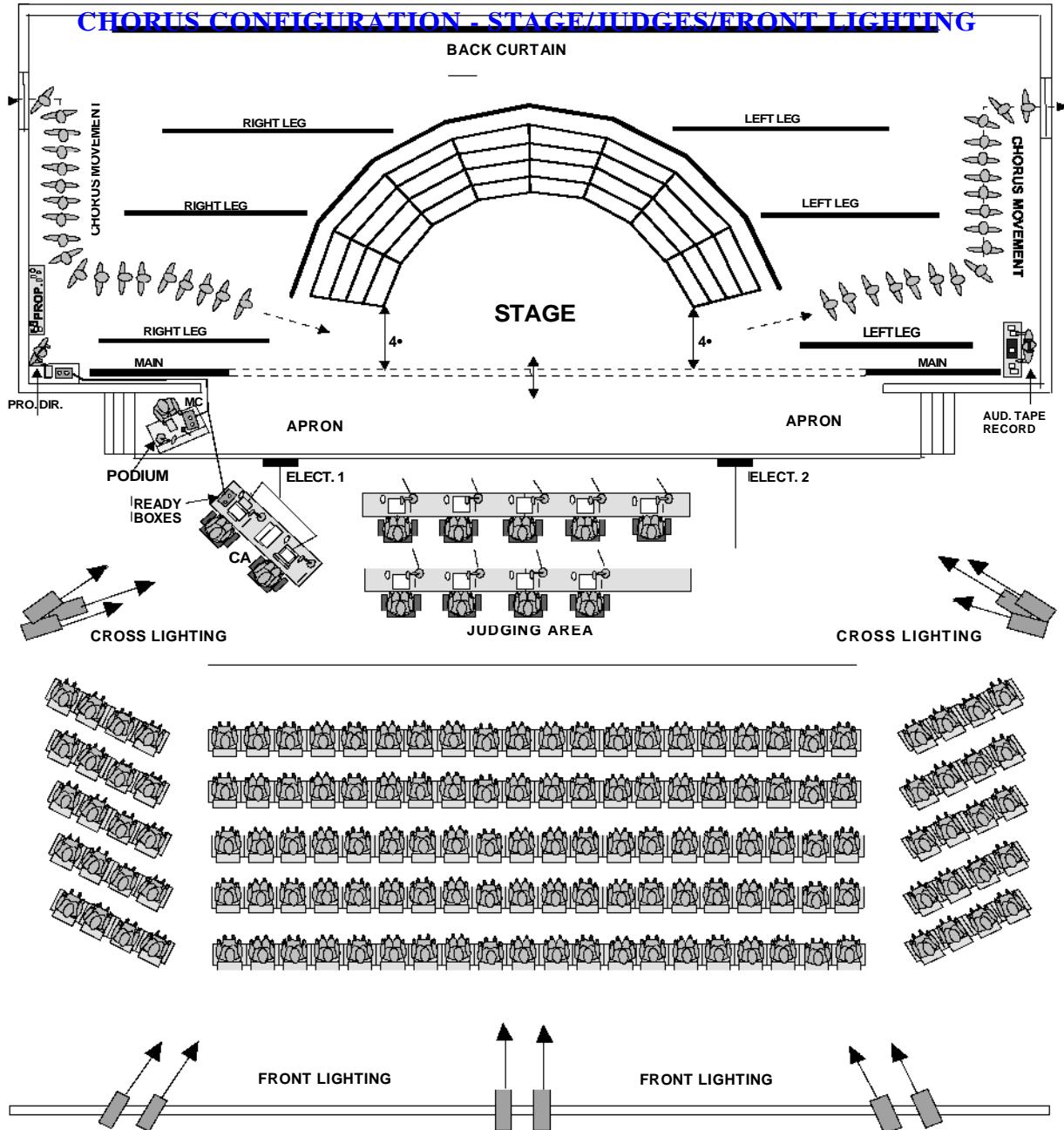

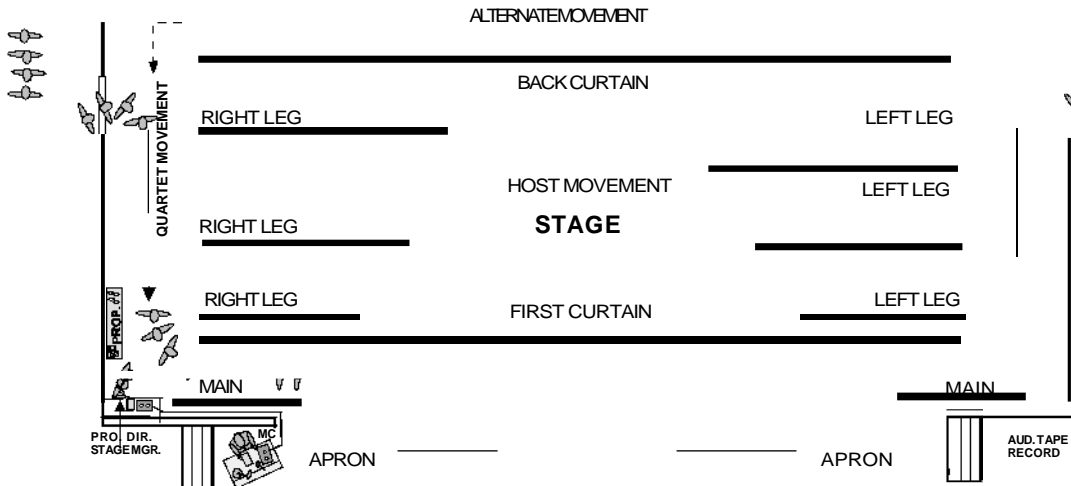
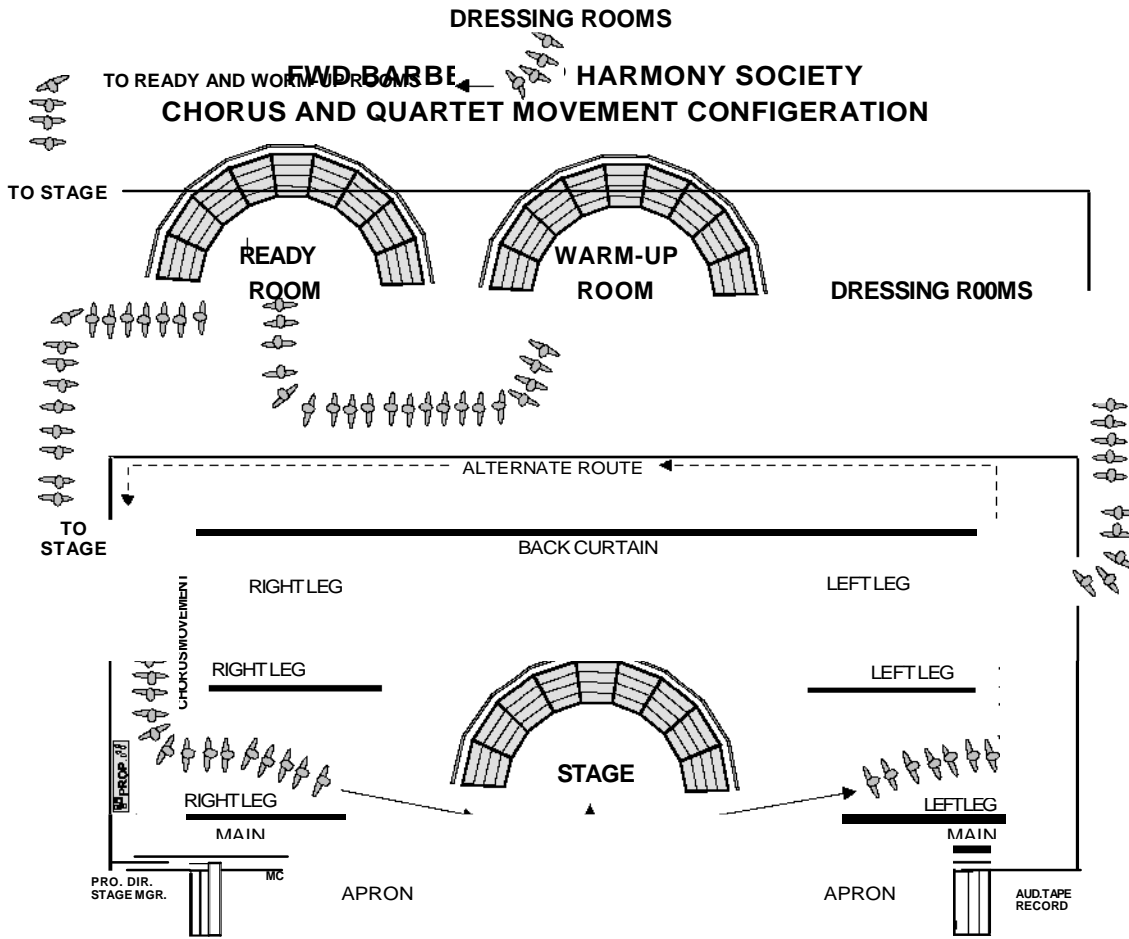



**BARBERSHOP HARMONY SOCIETY
SPEBSQSA, Inc.**

FAR WESTERN DISTRICT

**PART C - SECTION 3
SPRING/DIVISIONAL
CONVENTIONS/CONTESTS**

**THEATER
SAMPLES**

TS-01



**FAR WESTERN DISTRICT
BARBERSHOP HARMONY SOCIETY**

2009

SAMPLE FALL MOVEMENT MONITOR LOCATIONS

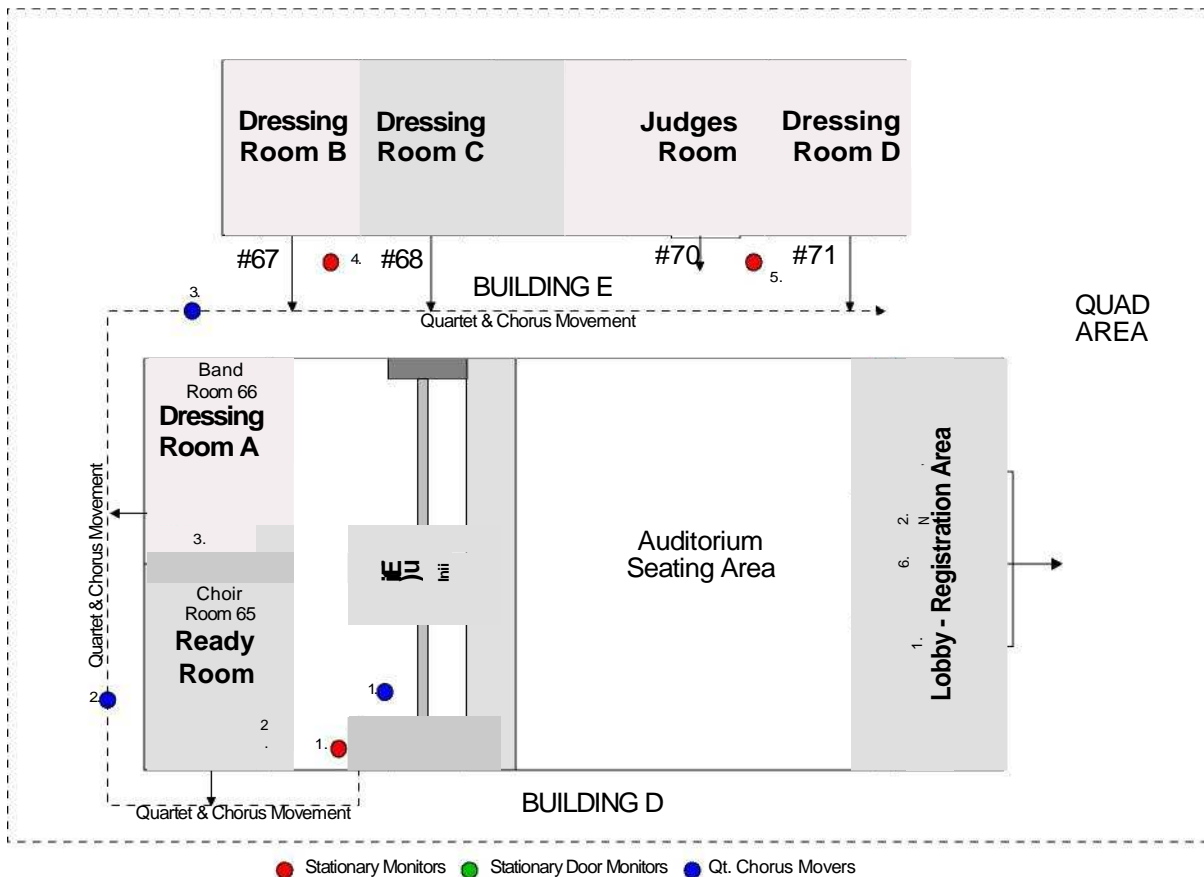



**FAR WESTERN DISTRICT
BARBERSHOP HARMONY SOCIETY**

2009

SAMPLE MONITOR/MOVMEMENT WORKERS SCHEDULE

FWD CONVENTION/CONTESTS MONITOR/MOVMEMENT WORKERS SCHEDULE					
Time		Task	Qty.	Report to	Notes
Saturday					
08:00 AM	10:00 AM	Stage riser crew	8	Doug M.	Riser & choral shell setup
06:15 PM	10:30 PM	Stage Marshall	4	Carl T.	Marshals to assist in stage activity
06:15 PM	10:30 PM	Quartet Ushers	6	Fred K.	Usher Quartets to and from the stage door.
06:15 PM	10:30 PM	Aud. Ushers/Door Att.	12	Kiech K.	Control Doors/Usher Convention Attendees
10:00 PM	?	Stage Riser Crew	8	Doug M.	After the Quartet Semi-Finals
10:15 AM	3:00 PM	Stage Marshall	4	Carl T.	Marshals to assist in stage activity
10:15 AM	3:00 PM	Aud. Ushers/Door Att.	12	Kiech K.	Control Doors/Usher Convention Attendees
10:45 AM	3:00 PM	Stage riser crew	6	Doug M.	Riser-choral shell shift (3-4) during ch. contest
10:15 AM	3:00 PM	Chorus Ushers	6	Fred K.	Usher choruses to & from the stage door
06:15 PM	10:30 PM	Quartet Ushers	6	Fred K.	Usher Quartets to and from the stage door.
06:15 PM	10:30 PM	Aud. Ushers/Door Att	12	Kiech K.	Control Doors/Usher Convention Attendees
06:15 PM	10:30 PM	Stage Marshall	4	Carl T.	Marshals to assist in stage activity
06:45 PM	?	Stage riser crew	6	Doug M	Riser-choral shell shift prior to int. Sat. night
10:30 PM	?	Stage riser crew	8	Doug M.	Riser-choral shell strike after show Sat. night

Revised 01/09

Back Stage Flow

The following approach will be used to organizing the backstage flow during the contest events. The plan will move the contestants as little as possible, and still give them plenty of time to warm-up.

Upon arrival, choruses & quartets can get directions to the assigned dressing/warm-up rooms at **the arena check-in table**. This will begin the cycle.

To direct the quartets & choruses through the flow **one escort** will be assigned to **each "leg"** of movement backstage, as follows:

Quartet	Choruses
1. Check-in to warm-up room	1. Dressing area to warm-up room
2. Warm-up room to backstage	2. Warm-up room to backstage
3. Stage to photo room (if used)	3. Stage to photo risers

At each major location, a stationary person with a radio will be posted:

Quartet	Choruses
1. Check-in area	1 Dressing area
2. Warm-up rooms' hallway	2. Warm-up room
3. Backstage	3. Backstage

When **quartets** finished their first song, the backstage person will call (by radio) for the next quartet to head from the warm-up rooms to the stage.

As soon as a **chorus** began moving onstage, the backstage radio person initiate movement of two other choruses: one to the stage, one to the warm-up area. Adequate notice will allow each group to arrive at the stage in plenty of time.

By having the **same person** in charge of **each leg for the entire session**, they get to know the route much better, and get to know exactly how long it would take to get from point to point.

SAMPLE MONITOR SESSIONS AND MANPOWER
Saturday Morning – Chorus Finals

Name	Location	Movement
Escort 1	Arena	Dressing to (?) Room
Escort 2	Arena	Dressing to (?) Room
Escort 3	(?) Room	(?) Room to backstage
Escort 4	(?) Room	(?)
Escort 5	Backstage	Backstage to photos
Radio 1	Arena/check in table	Stationary – dressing area
Check-in 1	Arena/check in table	Stationary – dressing area
Radio 2	(?) Room	Stationary – warm-up
Radio 3	(?) Room	Stationary – warm-up
Radio 4	Backstage	Stationary – backstage

Saturday Evening – Quartet Finals/Senior

Name	Location	Movement
Escort 1	(?) Room	Dressing rooms to backstage
Escort 2	(?) Room	Dressing rooms to backstage
Radio 1	(?) Room	Stationary – dressing rooms
Radio 2	(?) Room	Stationary – dressing rooms
Radio 3	Back stage	Stationary – backstage door
Check-in 1	Arena table	Table to dressing rooms
Check-in 2	Arena table	Stationary – arena table

Saturday Evening – Show of Champions

Name	Location	Movement
Escort 1	Arena	Dressing to warm-up
Escort 2	(?) Room	Warm-up room to backstage
Escort 3	East side	Dressing rooms to back stage
Radio 1	Arena/check in table	Stationary – dressing area
Radio 2	(?) Rooms	Stationary – warm-up
Radio 3	East side	Stationary – dressing rooms
Radio 4	Backstage	Stationary – backstage
Check-in 1	Arena table	Table to dressing rooms
Check-in 2	Arena table	Stationary – arena table

-End of Movement/Monitor--

TS-02



**FAR WESTERN DISTRICT
BARBERSHOP HARMONY SOCIETY**

2009

SAMPLE CONVENTION CHAIRMAN CHECK LIST OF THINGS TO BRING AND TO-DO

PHYSICAL ITEMS

Awards (Clements)
Pencils /Pens
Chapter Class B Uniform
Printed Items for Check-In Table
Flashlight
Printed List of Registrations (3)
Programs (500 Copies)
Health-Pills/Sugar Snacks/Water
Registration Badges (Shova)
Judging Area Equipment Box (Girvin)
Registrations (Originals)
Money Box for Reg. Area (Shova)
Signs
Westminster Donation Can
Score Sheet Paper (2)
Judges Paper (1)

AUDITORIUM/STAGE

Back Stage Chorus Flow Chart
Riser Schematic
Back Stage Quartet Flow Chart
Show of Champions Flow Chart
Chorus Stage Flow
Signs
Lighting Schematic
Sound Schematic & Info Sheet
Pens/ Pencils/Markers
Work Sheet & Workers
Quartet Stage Flow
Sign Glue

HAND OUTS QUARTETS/CHORUSES

Quartet/Chorus Packet

REGISTRATION DESK/AREA

Badges Printed – Boxes (Shova)
Reg. Applications Late
Markers/Names on Reg. Badges (Shova)
Reg. Badges Late/On Site (Shova)
Money Box (Shova)
Reg. Badges Pre-Paid Printed
Pencils/Markers
Registration Computer Printout
Plastic Badge Holders (Shova)
Signs
Programs
Westminster Donation Can
Orig. Reg. Applications Envelopes.
Workers List

BACKSTAGE BOOK

Addresses/Phone #
Program Layout
Applications Qt/Chorus Comp.
Qt/Chorus Back-Stage Flowchart
Bank Deposit Slips (Copies)
Qt/Chorus Movement Schedules
Entry Forms Qt/Chorus
Reg. Print-Out Pre-Paid
Flyer/Letters/Etc. (Copies)
Alta Loma HS Contract
FWD Statements
Show of Champions Flowchart
Hotel Contract
Society Insurance Flyer (Copy)
Vouchers To Pay
Paid Vouchers
Workers/Volunteers List

BACK-STAGE CONVENTION/CONTESTS INFORMATION FOLDER

Chorus Movement Schedule
Alta Loma HS Ch. Flow Schematic
Chorus Stage Flow Schematic
Facilities Schematic
Lighting Schematic
Qt. Flow Schematic
Qt/Chorus Awards List
Workers/Volunteers Sheets
Riser Schematic
Writing Note Pad
Sound/Audio Schematic
Qt. Stage Flow Schematic
Show of Champions Schematic
Qt. Movement Schedule

-End of Check List-



**FAR WESTERN DISTRICT
BARBERSHOP HARMONY SOCIETY**

CONTRIBUTORS TO THIS MANUAL

BOB CATHAWAY

2009 FWD Chairman of the Events Committee

DOUG MADDOX

FWD Production Director and Events Tech. Consultant

GLEN GLANCY and BILL LIGHTNER

BHS Sound Tech. Consultants

CARL TRUMAN

FWD Events Movement/Monitor Tech. Consultant

DICK GIRVIN

FWD Secretary and Events Tech Consultant

And

FRITZ GRUNENWALD

**Typesetting, Graphics and Layout
FWD Events Tech. Consultant**

-End of Spring/Divisional Convention Manual-